

Cobolt Tor™

High Performance | Q-switched laser

355 nm
532 nm
1064 nm



CONTENTS

| | | |
|------------|--|-----------|
| 1. | Introduction | 4 |
| 2. | Safety | 5 |
| 2.1. | General | 5 |
| 2.2. | Safety features | 6 |
| 2.3. | Equipment Safety | 6 |
| 2.4. | Warning and Identification Labels | 7 |
| 3. | Overview | 8 |
| 3.1. | Model number | 8 |
| 3.2. | Configuration | 8 |
| 3.3. | Laser Head | 9 |
| 3.4. | Controller | 9 |
| 3.5. | Controller Cable | 10 |
| 3.6. | Thermal Management | 10 |
| 3.7. | Power Supply Requirements | 11 |
| 4. | System Description | 12 |
| 4.1. | Specification | 12 |
| 4.2. | Mechanical Drawings | 14 |
| 4.3. | Remote Interlock Connector | 16 |
| 4.4. | Direct ON/OFF control | 16 |
| 4.5. | Pin assignment | 17 |
| 5. | Operating Instructions | 18 |
| 5.1. | Installation start-up operation | 18 |
| 5.2. | Shutdown procedure operation | 18 |
| 6. | Operating modes | 19 |
| 7. | Operation via data port | 20 |
| 7.1. | Remote Interface Configuration | 20 |
| 7.2. | Establishing serial port communication | 20 |
| 7.3. | Communication commands | 21 |
| 7.4. | Installation of the USB driver | 22 |
| 8. | Cobolt Monitor™ Software | 25 |
| 8.1. | Installation | 25 |
| 8.2. | Software instructions | 25 |
| 9. | Troubleshooting | 29 |
| 10. | Warranty and Maintenance | 29 |
| 11. | Service | 29 |
| 12. | Compliance (CDRH models only) | 30 |
| 13. | Disclaimer | 31 |

1. Introduction

The Cobolt Tor™ Series lasers are high performance Q-switched diode pumped lasers. The sophisticated cavity design of these lasers provides a unique combination of compact size and performance (short ns-pulses, high pulse repetition rates, exceptional pulse-to-pulse stability in a high-quality beam).

The Cobolt Tor™ lasers are equipped with a pulse-count feed-back loop to ensure minimum drift in output power and active repetition rate measurement and provide a trigger output signal for convenient synchronization with other equipment.

The Cobolt lasers are manufactured in Sweden by Cobolt AB, a part of HÜBNER Photonics. Using proprietary HTCure™ technology the lasers are packaged into a sealed laser head, offering an outstanding level of robustness and reliability, and making these lasers highly suitable for OEM integration into demanding environments.

The combination of compact size, high level of robustness, and outstanding performance make the Cobolt Tor™ Series lasers ideal light sources for a large variety of industrial and scientific applications, including LIBS, LIDAR, marking, photo-acoustics, micro-dissection, MALDI-TOF, range-finding, and micro-machining.

2. Safety

2.1. General

Cobolt Tor™ lasers are Class IIIB (3B) and Class IV (4) laser products that emit laser radiation within the ultra-violet (UV), visible and Near Infrared (NIR) spectrum. Residual emissions from the pump diode are contained within the laser head housing via filtering optics. The residual emission does not exceed Laser Class 1.



Eye and skin exposure to direct or reflected laser light is hazardous and may be extremely harmful. Always wear eye protection appropriate to the beam wavelength(s) and intensity and never look directly into a laser beam. Laser radiation may ignite flammable materials and combustible gasses in the beam path and, in event of ignition, fumes may be generated. All equipment used in close proximity to the laser beam should be suitably fire resistant and the facility should be properly ventilated. It is advised to perform a risk assessment for the facility and equipment prior to using the laser. In the case of integration into a larger system, laser safety compliance must be evaluated in the end product. The device must be handled by skilled personnel experienced with lasers, in a laboratory environment and with access to adequate laser safety equipment. The laser clearly displays a yellow warning label that shows the location of the laser beam aperture. This label must be visible unless the laser beam is totally enclosed. If the laser does not function, do not attempt to open any of the units, or the warranty will be voided. Contact your local sales representative for consultancy and to request an RMA number (see back cover for contact information).

The table below describes the maximum energy density in J/cm² used for safety calculations and the appropriate level of eye protection in terms of optical density (OD) for each product line.

| Product | Laser Class | Warning Label Power (mW) | Max Pulse (µJ)* | Max Energy Density (mJ/cm ²)** | Eye Protection Requirement*** |
|---------------------|-------------|--------------------------|-----------------|--|-------------------------------|
| Cobolt Tor™ 355 nm | 3B / IIIB | 350 | 50 | 18 | > OD 4 / I,R L5 |
| Cobolt Tor™ 532 nm | 4 / IV | 1500 | 214 | 43 | > OD 5 / I,R L6 |
| Cobolt Tor™ 1064 nm | 4 / IV | 2000 | 286 | 45 | > OD 4 / I,R L6 |

* Max Pulse (µJ) = Warning Label Power (W) ÷ Repetition Rate at bottom tolerance (Hz)

** Max Energy Density (mJ/cm²) = Warning Label Pulse (mJ) ÷ Beam Area at bottom tolerance (cm²)

*** Eye protection (OD) = Log₁₀(60825-1 Emission Limit : Class 1 (µJ) ÷ Max Pulse (µJ)), rounded up to the next integer/See EN 207



CAUTION Use of controls or adjustments or performance of any procedures other than those specified herein may result in exposure to hazardous radiation.

2.2. Safety features

The laser is equipped with all required safety features as described in the laser safety standard IEC 60825-1. If any part of the delivered equipment is replaced with a part not supplied by the manufacturer or if the equipment is not properly grounded system may not conform to CE / CDRH compliance standards listed in Section 12. Disabling any of the safety features nullifies the CE marking and violates the laser safety standard.

Remote Interlock Connector

The remote interlock connector is a connector which permits the connection of external controls placed apart from other components of the laser product. When the terminals of the connector are open-circuited, emission is interrupted and no radiation will be accessible. The remote interlock connector permits easy addition of an external interlock in laser installation. See Section 4.3 for a detailed description of the remote interlock circuit and operation.

Manual Shutter (Beam Stop)

The laser head is equipped with a manual shutter, which functions as the beam stop, capable of preventing human access to laser radiation. The aperture location, the open and close positions of the shutter are indicated on the top surface of the laser head.

Key Control

The CDRH compliant model comes with a key-switch on the Controller which must be connected for the laser to operate. When the key is in the OFF position, the laser is prevented from emitting. The key must be actively turned to the ON position each time the laser is powered on. When the key is removed from the system laser radiation is not accessible.

Laser Radiation Emission Warning

The Controller incorporates information LEDs which display whether power is connected, the laser is on, or a fault has occurred. The "ON" LED is illuminated whenever the device is emitting or could emit light. See Section 3.4 for details on the controller. The emission warning indicators are also visible in the Cobolt Monitor™ software, see Section 8 for details on the control software.

2.3. Equipment Safety

Always install all power supplies used in the laser system to properly grounded power outlets. The laser head and controller must be mounted on a common ground plane, such as an optical table. Cobolt lasers contain a laser diode which is sensitive to electrostatic discharge (ESD).

2.4. Warning and Identification Labels

The upper face of the laser head contains a yellow label with laser safety warning and classification information, the wavelength and maximum power of the unit. It also shows the location of the laser beam from the aperture and indicates the open and close positions of the manual shutter. This label must be visible unless the laser beam is totally enclosed. A silver label showing information about the laser model, manufacturer date and location, the power supply voltage and the current, is located on the laser head. Lasers shipped to customers in the USA also contain a label of CDRH compliance.

Manufacturer Identification Labels



OEM Label

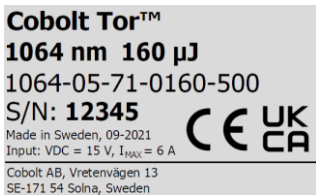

CE marking for CDRH models only



Aperture Warning Labels

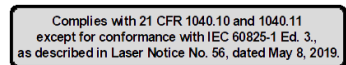

Laser Notice No. 56 Label
CDRH models shipped to USA

3. Overview

Cobolt Tor™ Series laser systems consist of four main parts: the laser head, the controller, the cable and the power supply (not shown). The cable provided should always be used to connect the laser head with the controller. Always install the laser system to a properly grounded power outlet.

3.1. Model number

Cobolt lasers are sold in two configurations: OEM and CDRH, described in Section 3.2. The model numbers are composed as described below.

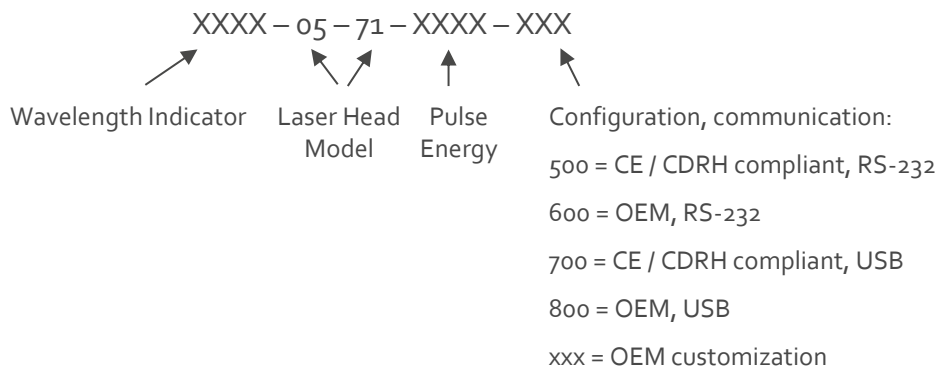

3.2. Configuration

3.2.1. CDRH Compliant

The CDRH compliant system is supplied with a key switch on the controller, which must be connected, along with a remote interlock connector. Once power is supplied, laser radiation starts when the key is turned from the OFF position to the ON position. The status of operation can be monitored via LEDs on the Controller. Setting the key to its OFF position puts the laser in stand-by mode. **The CDRH model is CE compliant.**

The standard CDRH model consists of:

- Laser head
- Controller with key switch
- Keys
- 1 m Controller Cable
- 15 V/ 6 A power supply unit

3.2.2. OEM

The OEM system is supplied **without** a key switch on the controller. Connecting the power supply to the controller initiates an automatic start-up sequence. If the remote interlock is connected, laser radiation will start automatically as soon as power is supplied and internal temperatures are stabilized.

The OEM model consists of:

- Laser head
- Controller
- Controller Cable
- 15 V/6 A power supply unit

3.3. Laser Head

The laser head contains a passively Q-switched diode-pumped solid state nanosecond pulsed laser cavity and thermoelectric coolers (TEC). The laser head also contains a pulse monitoring feed-back loop that measures the repetition rate and ensures minimum drift in output power. The laser beam is not collimated.



The Cobolt Tor™ laser head (back side)

The laser head receives electrical power and control signals from the controller via a 26-pin cable. The laser head has a manual shutter as well as a laser hazard label and a laser classification label (see Section 2.4). In addition, the laser head features an SMA connector for direct monitoring of pulse parameters and delivering a trigger-out analog signal from the measured laser pulse (see Section 4.1.3)

3.4. Controller

The Controller supplies driving current and control signals to the laser head. All laser heads are delivered with a controller. The operation set points are specific to each Laser Head and have been fixed during manufacturing. The operation set points are stored in the laser head so the controller can be interchanged or replaced.

The status of the laser operation is given via LED indicators:

- POW* (green light) Power is supplied.
- ON* (orange light) Laser light is on in constant current mode.

- LOCK** (orange light) Laser light is on and the output power has been locked to set point.
The laser is operating according to specifications.
- ERR** (red light) An error has occurred. No laser light.

When power is supplied to the controller, regardless of on/off state, the temperature control elements are operating to reach set point values. The controller includes a remote interlock connector, pin 1-2 according to Section 4.3. The operation of the laser can be controlled and monitored via the data port that supports either USB or RS-232 communication (see Section 7 for further details). RS-232 controllers may also be delivered with a RS-232 to USB adapter.

3.5. Controller Cable

The controller cable connects the laser head to the controller. The standard (CE compliant) cable length is 1 m long. The cable has a minimum bending radius 8 cm. When connected care should be taken not to bend or break any of the 26 pins.

3.6. Thermal Management

To ensure operation within given specifications and for the warranty to be valid, the Laser Head must be attached to a heat sink providing a thermal resistance of <math><0.2 \text{ K/W}</math>. This value is the difference between the maximum allowed Laser Head base plate temperature ($50 \text{ }^\circ\text{C}</math>) and the maximum specified ambient temperature at the air-heatsink interface ($40 \text{ }^\circ\text{C}</math>), divided by the maximum power dissipated from the laser ($\sim 50 \text{ W}</math> for the highest power models at high ambient temperatures). The mounting surface should be flat (within $\pm 0.05 \text{ mm}</math> over mounting surface). It is recommended to use a thermal heat compound between the Laser Head and the heat sink to provide good thermal contact. The Cobolt 'HS-04 Laser Head Heatsink with fans' meets these requirements, see hubner-photonics.com for more information on heat sinks.$$$$

For assistance in thermal management and system integration, please contact Hübner Photonics' technical support.

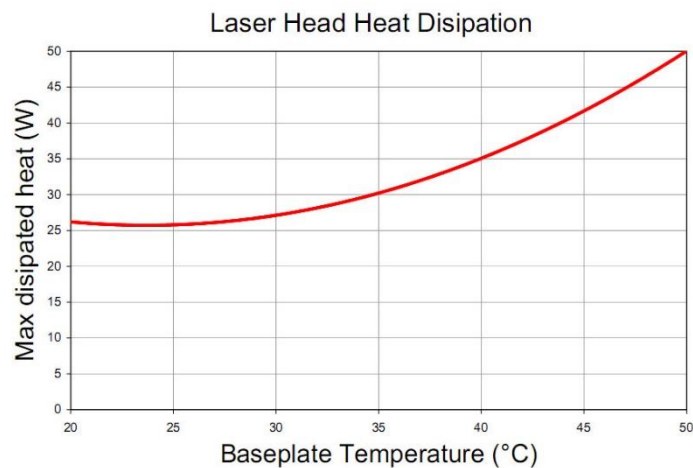

Heat Sink Requirements and typical maximum heat dissipation for Cobolt Tor™ Series.

3.7. Power Supply Requirements

An appropriate power supply Unit (PSU) is supplied by the manufacturer with the laser and must be plugged into a properly grounded standard power outlet. The output from this PSU is 15 VDC/ 6 A. The power supply accepts 100 – 240 V AC and 50-60 Hz. Ripple and noise 1% peak-peak max, 20 MHz bandwidth. The accepted voltage range is 11 V - 28 VDC; full performance is only guaranteed at 15 VDC/ 6 A.

4. System Description

The information presented here is believed to be accurate and is subject to change without notice. The specifications contained herein cannot be guaranteed outside of normal operational conditions. Specifications are guaranteed at 100% of nominal energy/ power.

4.1. Specification

4.1.1. Optical Specifications

| | | | |
|--|---|------------|--------------|
| Centre wavelength ¹ (nm) | 354.8.1± 0.3 | 532.1± 0.3 | 1064.2 ± 0.6 |
| Pulse energy (µJ) | 18 ± 3 | 60 ± 5 | 160 ± 15 |
| Peak power ² (kW) | > 3 | > 11 | > 29 |
| Repetition rate (kHz) | > 7 | | |
| Pulse-to-Pulse Jitter (µs) | < 1 | | |
| Pulse duration (ns) | 4 ± 1 | | |
| Long-term repetition rate stability (8 hours, (±3 °C)) | < 3% | | |
| Spatial mode | TEM ₀₀ , M ² <1.3 | | |
| Divergence, full angle (mrad) | 5 ± 2 | 8 ± 1 | 10 ± 1 |
| Beam Diameter at aperture (mm) | 0.9 ± 0.3 | 1.0 ± 0.2 | 1.2 ± 0.2 |
| Beam symmetry at aperture | > 0.65 : 1 | > 0.85 : 1 | > 0.90 : 1 |
| Beam angle accuracy (mrad) | < 5 | | |
| Beam position accuracy (mm) | < 1.0 | | |
| Polarization ratio (linear, vertical) | > 100:1 | | |
| Residual emission | < Class 1 | | |

1. The wavelength is specified in air.
2. Assuming a top hat profile, Peak Power (kW) = Pulse Energy (µJ) at bottom tolerance ÷ Pulse width (ns) at top tolerance

4.1.2. Operation and Environmental Specifications – Laser Head

| | |
|---|-----------------------------------|
| Power supply | 15 VDC, 6 A. (11-28 VDC accepted) |
| Power consumption, total system (Laser Head + Controller) | < 63 W (typical ~30 W) |
| Maximum heat dissipation of Laser Head | < 50 W (typical ~20 W) |
| Maximum Laser Head baseplate temperature | 50°C |
| Warm-up time, from OFF | < 5 min |
| Ambient temperature, operation | 10 – 40 °C |
| Ambient temperature, storage | -10°C to +60 °C |
| Humidity | 0-60 % RH non-condensing |
| Ambient Air pressure | 950-1050 mbar |
| Heat sink thermal resistance, Laser Head | < 0.2 K/W |

4.1.3. Electrical Interfaces - Controller

| Interfaces | Connector | Function |
|-----------------------------------|-----------------------|---|
| Input power | Kycon KPJX-45, 4-pin | Power supply to Controller |
| Laser Head to Controller | HD-sub 26-pin, male | Connection to Laser Head |
| Controller to Laser Head | HD-sub 26-pin, female | Connection to Controller |
| Data port | USB-type mini B | Control and monitoring via control commands |
| Remote interlock & Analog signals | Molex 90130-3206 | Analog input 5 – 12 V => Laser ON Analog input <2.7 V => Laser OFF |
| Optical pulse monitor | SMA connector | Analog signal (1-1.5 V), impedance 50 Ohm |

4.1.4. Mechanical Interfaces

| | |
|---------------------------------|---|
| Dimensions: | |
| Laser Head | 125 x 70 x 45 mm (4.9 x 2.8 x 1.8 inches) |
| Controller | 190 x 72 x 28 mm (7.5 x 2.8 x 1.1 inches) |
| PSU dimensions | 115 x 50 x 35 mm (4.6 x 2 x 1.4 inches) |
| Fixation holes, Laser Head | ∅ = 4 x 4.5 mm (M4) ; 115 mm x 55 mm |
| Fixation holes, Controller | ∅ = 4 x 6.4 mm (M6); 178 mm x 51 mm |
| Cable (Laser Head – Controller) | 1 m length, >8 cm bending radius |
| Laser Head weight | <0.6 kg |

4.2. Mechanical Drawings

4.2.1. Laser Head

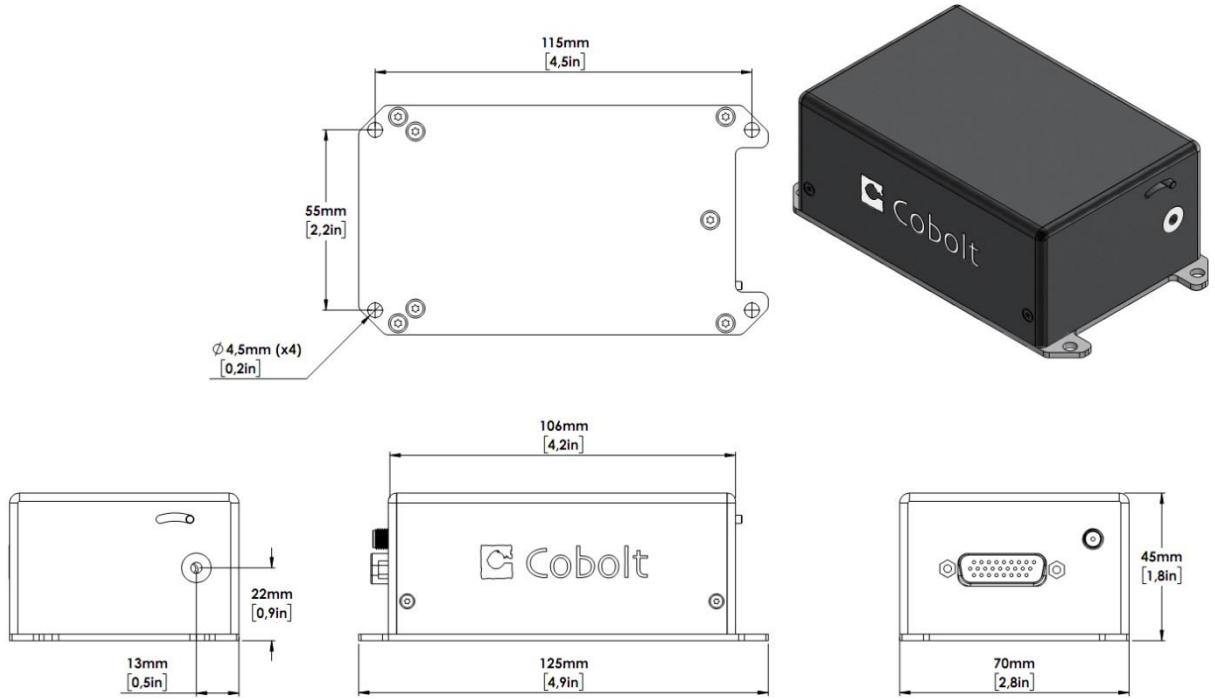

Laser head mechanical outline. Dimensions in mm [inches].

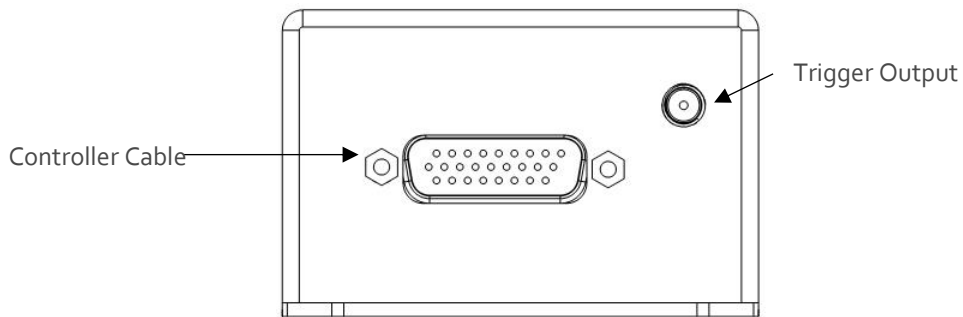

Connector location Laser Head

4.2.2. Laser Controller

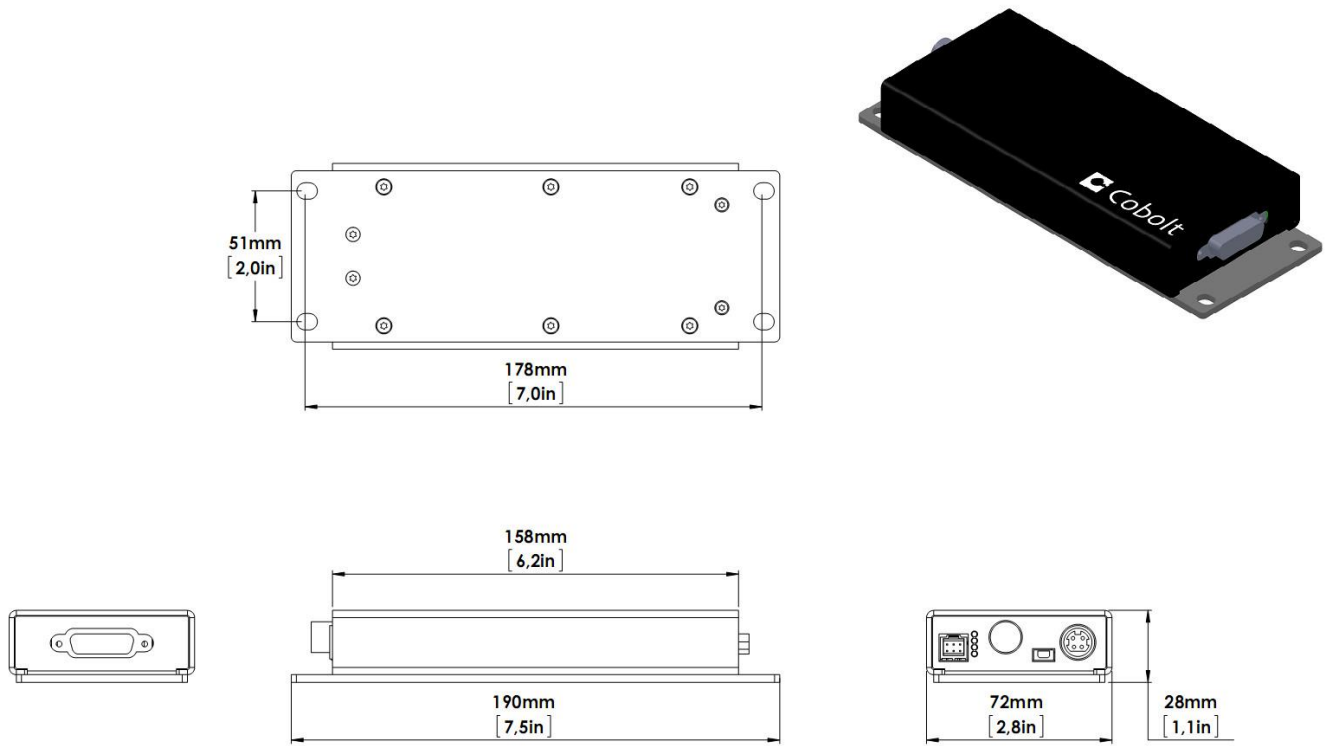

Controller mechanical outline. Dimensions in mm [inches].

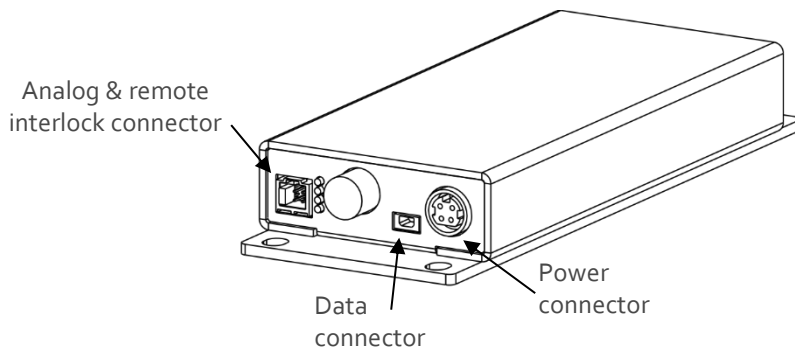

Connector location Controller

4.3. Remote Interlock Connector

The remote interlock connector is located at pin 1 and 2 of the Molex connector on the controller (see Section 4.5). The connector can be short-circuited with an interlock jumper (included at delivery) for operation of the laser. To use the remote interlock connector with an external switch, connect a pin 1 and 2 on a Molex plug. After the remote interlock connector has been opened the laser will need to be reset by disconnecting from and then reconnecting to the power supply in order to start again. Alternatively, it can be re-started using a special sequence of commands, see Section 7.3 for further details. The signal level is between 0 V and +5 V with a pull up resistor, and the current required to ground the remote interlock connector is 5 mA. The time delay in the hardware is < 1ms, but after filtering by the firmware the reaction time is extended to < 20ms.

4.4. Direct ON/OFF control

The Direct On/Off Control feature enables turning the laser ON/OFF using a 5-12 VDC signal. After having configured the Controller for Direct Control operation, the laser can only start-up when 5-12V VDC (max 12.5 VDC) is applied to pin 3 on the analog connector with 0 VDC on pin 2 as reference. Shifting the signal to 0 VDC on pin 3 will turn the laser off and put the laser in stand-by mode (status LED:s is POW and not flashing).

This function is not available for CDRH compliant models.

! Note: This input only controls the on/off state of the laser and cannot be used to modulate the laser output.

4.5. Pin assignment

4.5.1. Analog connector & Remote interlock connector

Manufacturer Molex 90130-3206, mates with 90143-0006.

| Pin | Function |
|-----|--|
| 1 | Remote Interlock (connect to pin 2 for enable) |
| 2 | 0 V - GND |
| 3 | Remote On/Off (+5 V Input) |
| 4 | TST (Internal Cobolt use only) |
| 5 | LED "Laser on" (5 V) |
| 6 | LED "Error" (5 V) |

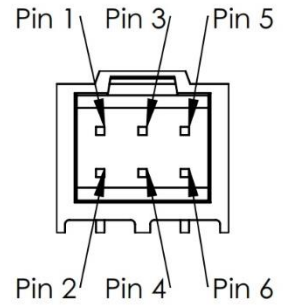

4.5.2. Power connector

Kycon KPJX-4S, mates with Kycon KPPX-4P. Grounded shield.

| Pin | Function |
|-----|------------|
| 1 | 0 V |
| 2 | +11-28 VDC |
| 3 | 0 V |
| 4 | +11-28 VDC |

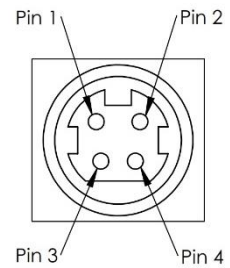

4.5.3. Data connector

Connector USB-type, manufacturer Hsuan Mao C8320-05BFDSBo, mates with connector mini-B.

| Pin | Function |
|-----|---------------|
| 1 | +5 V |
| 2 | D- |
| 3 | D+ |
| 4 | Not connected |
| 5 | 0 V (GND) |

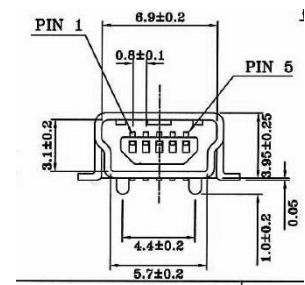

5. Operating Instructions

As standard, all lasers are delivered with the Controller set in Auto-start mode. As soon as power is supplied to the Controller the temperature control elements are operating to reach set-point values and the laser emission will start, unless the key-switch is enabled (CDRH model).

5.1. Installation start-up operation

1. Mount the laser head on a suitable heat sink (see Section 3.6).
2. Ensure that the remote interlock jumper is connected.
3. Connect the laser head to the controller with the cable and fasten screws at both ends.
4. Connect the 15 VDC power supply to the mains outlet and then to the controller.
5. The laser now goes through the following auto-start sequence:
 - Temperature stabilization (1-2 min). Status LEDs: POW flashing, then POW goes on.
 - Turn key switch to start the laser. Status LEDs: ON goes on (CDRH model only)
 - The laser starts (light is emitted) in a constant warm-up current constant for 60 sec.
Status LEDs: ON goes on.
 - The laser locks to pre-set output power (<2 min) and operates according to specifications.
Status LEDs: LOCK goes on.

! Note: If the power does not match the power as stated on the test sheet see Section 11: Service for more information.

5.2. Shutdown procedure operation

1. Turn the key switch to OFF first (CDRH models only).
2. Disconnect PSU from mains outlet.
3. Disconnect Controller from PSU.

6. Operating modes

Cobolt Tor™ series lasers are delivered in constant current mode. CDRH/CE compliant models may be used in constant current and burst mode only.

6.1.1. Constant current

The pump laser diode delivers a constant current. The constant repetition rate loop is inactive when this mode is selected. The actual repetition rate will still be displayed in the Cobolt Monitor™ software (see Section 8.2)

6.1.2. Burst mode

In burst mode, the laser diode current is modulated which allows in bursts of pulses to be emitted repeatedly. The “On-Time” sets the time (in ms) where the laser diode current is set to “I-High”, and the “Off-time” sets the time (in ms) where the laser diode current is set to “I-Low”. Please, refer to Section 8.2 for the Cobolt Monitor software interface.

The burst mode can be used in numerous ways, but a typical use would be to set the “I-Low” just below the laser threshold and the “I-High” at a laser diode current giving desired output power. The result would be an on/off modulation of the laser set by the On/Off-times where a burst of pulses is emitted during the On-time. The pulse repetition rate is dependent on the laser diode current and consequently the number of pulses emitted in the On-state is dependent on both the “On-time” and “I-High”.

As an example, if the pulse repetition rate at the set “I-High” is 7 kHz and the On-time is 7 ms, then there will be a burst of approximately 49 pulses during the On-time.

6.1.3. Constant repetition rate (OEM only)

The pulse repetition rate is monitored internally, and a feed-back loop assures that a constant repetition rate is delivered by making small adjustments of laser diode current. Using the lasers in constant repetition rate mode is not compliant with the EMC/EMI 61326 standard for immunity to radiated electromagnetic fields according to IEC 61000-4-3 and thereby negates the CE compliance.

7. Operation via data port

Communication between the Cobolt Tor™ laser and a PC can be established via data port communication. Once communication is established, the device can be controlled and monitored using the Cobolt Monitor™ software or using custom made software using the commands listed in Section 7.3. The laser controller can be configured for either USB or RS-232 communication upon manufacturing. Please contact your sales representative for more support.

7.1. Remote Interface Configuration

RS-232 configured controllers

To communicate with a laser, a PC needs to have a serial port. Alternatively, a RS-232-to-USB converter can be used. The serial port settings are listed in Section 7.2.

USB configured controllers

When using Cobolt Monitor™ with Windows 10, the USB device is automatically detected. When using Windows 8 or earlier (e.g Windows 7, Vista, XP) it is necessary to install the Cobolt signed USB driver, please refer to Section 7.4. The computer will recognize the device as a virtual serial port and assign it a COM port.

7.2. Establishing serial port communication

Serial communication can be established with the laser using the following configuration:

- Baud rate: 115200
- No parity
- Termination for commands: CR
- Termination for answers: CR
- Byte size: 8 bits
- 1 stop bit

Commands to operate the lasers are listed in Section 7.3. All commands are case sensitive and command arguments must be delimited by a single space character (ASCII 32). Under no circumstances does the system initiate communication; it only transmits a response to each command, either a numerical value, a string or the acknowledgment string "OK". In the event that the system receives a command that it cannot interpret, it responds: "Syntax error: illegal command".

To get started using a Cobolt laser with a program written C++ or Python, please refer to our example codes at the Hübner Photonics GitHub: <https://github.com/cobolt-lasers>.

7.3. Communication commands

The laser is delivered with the Controller set in Auto-start mode (see section 5.1 for Auto-start sequence description). For system integration the Auto-start sequence can be disabled, and the following commands can be used to control the laser (NOTE some commands require Auto-start to be disabled but others will work when Auto-start is active). As long as power is supplied to the controller the temperature control elements are always operating to reach set-point values and the laser will be idle waiting for the next command. All arguments are in lower case and separated by a space (ASCII 32).

| Command | Function | Argument | Returned value |
|-----------|---|----------|--|
| sn? | Get serial number | | 32-bit unsigned integer |
| l1 | Laser ON Requires autostart disabled. Use this command for manual ON (OEM models). | | |
| @cob1 | Force Autostart Forces the laser into Autostart without checking if autostart is enabled (OEM models). | | |
| lo | Laser OFF Use this command for manual OFF (OEM models). | | |
| l? | Get laser ON/OFF state | | 0 = OFF, 1 = ON |
| leds? | Status of 4 LEDs | | Int [0:15] Bit 0 = "POWER ON" Bit 1 = "LASER ON" Bit 2 = "LASER LOCK" Bit 3 = "ERROR" 1 = LED on 0 = LED off |
| f? | Get operating fault | | 0 = no fault 1 = temperature error 3 = open interlock |
| cf | Clear fault | | |
| hrs? | Get laser head operating hours | | Float |
| ilk? | Get interlock state | | 0 = OK, 1 = interlock open |
| @cobas? | Get autostart enable state | | 0 = disabled, 1 = enabled |
| @cobasdr? | Get direct control enable state | | 0 = disabled 1 = enabled |
| i? | Get actual drive current | | Float (A) |

| | | | |
|--------|--|--------------|-------------|
| glc? | Read drice current setpoint | | Float (A) |
| slc | Set drive current | Float (A) | |
| rlf? | Read laser rep-rate | | Float (kHz) |
| glf? | Get laser rep-rate setpoint | | Float (kHz) |
| slf | Set laser rep-rate | Float (kHz) | |
| ebm | Enable burst mode | | |
| ecc | Enable constant current mode | | |
| sihigh | Set high-level (on-level) current used in burst mode | Float (A) | |
| silow | Set low-level (off-level) current used in burst mode | Float (A) | |
| stlon | Set on-time used in burst mode | Integer (ms) | |
| stloff | Set off-time used in burst mode | Integer (ms) | |

For restarting the laser with control commands after having opened the remote interlock switch, execute “cf” for clear fault followed by “@cob1” to restart the laser. On CDRH models the key switch is the only way to restart.

7.4. Installation of the USB driver

When connecting a Cobolt Tor™ with to a computer using Windows 8 or earlier (e.g Windows 7, Vista, XP) it is necessary to install the Cobolt signed USB driver. The USB driver can be downloaded from the Cobolt website (hubner-photonics.com). When installed, is will be possible to establish connection as described previously in this section. To install the USB driver in Windows 7 follow these instructions:

1. Go to the **Control Panel** and choose **Hardware and Sound**.

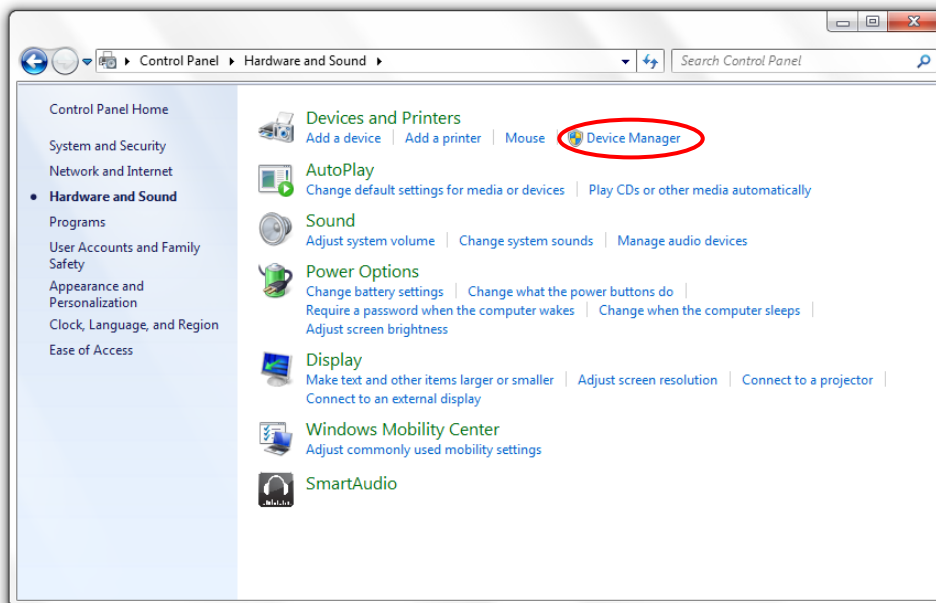

2. Under the **Devices and Printers** section, choose **Device Manager**.
3. Under **Other devices**, find the device called **Cobolt Laser Driver**. Right-click it and chose **Update Driver Software**.

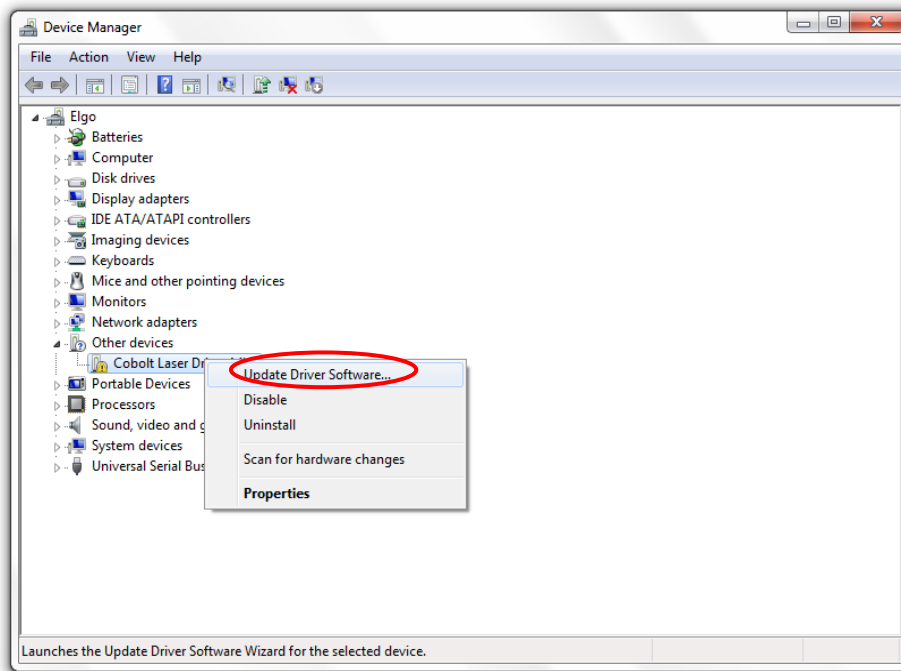

4. On the next screen chose the **Browse my computer for driver software** option.

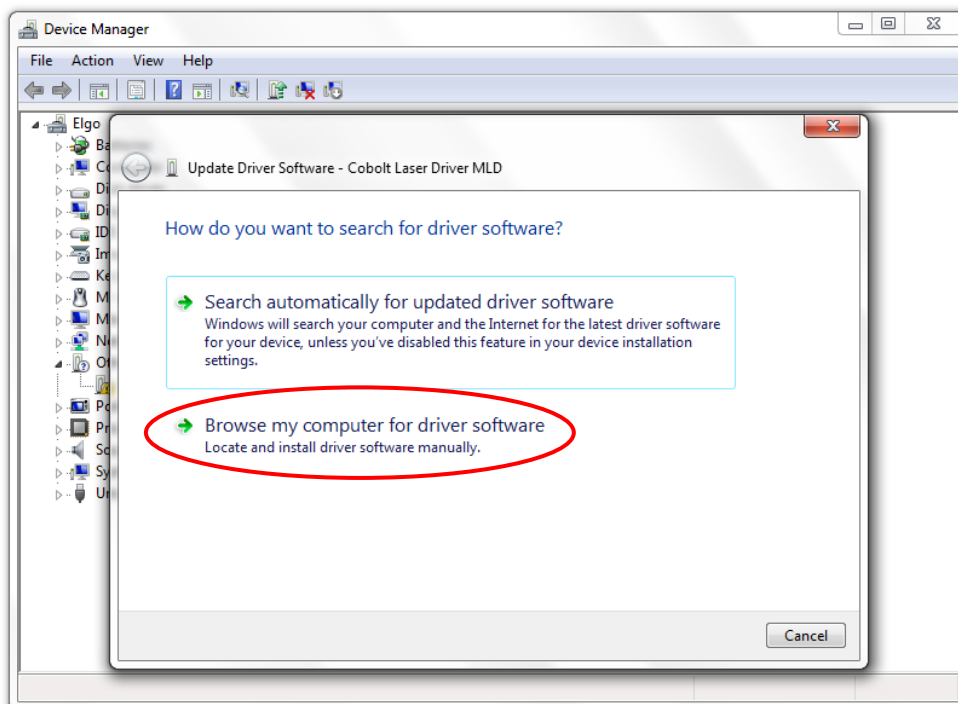

5. Click **browse**, and find folder on your computer where the USB driver is stored.

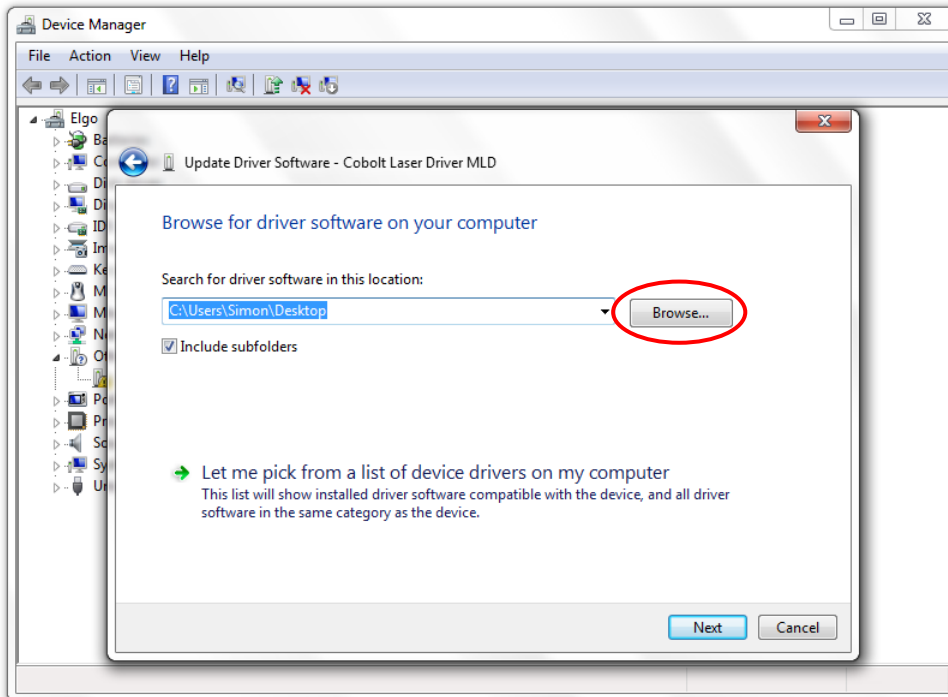

6. Windows security may warn you that the publisher of the driver is unverified. Choose **Install this driver software anyway**.

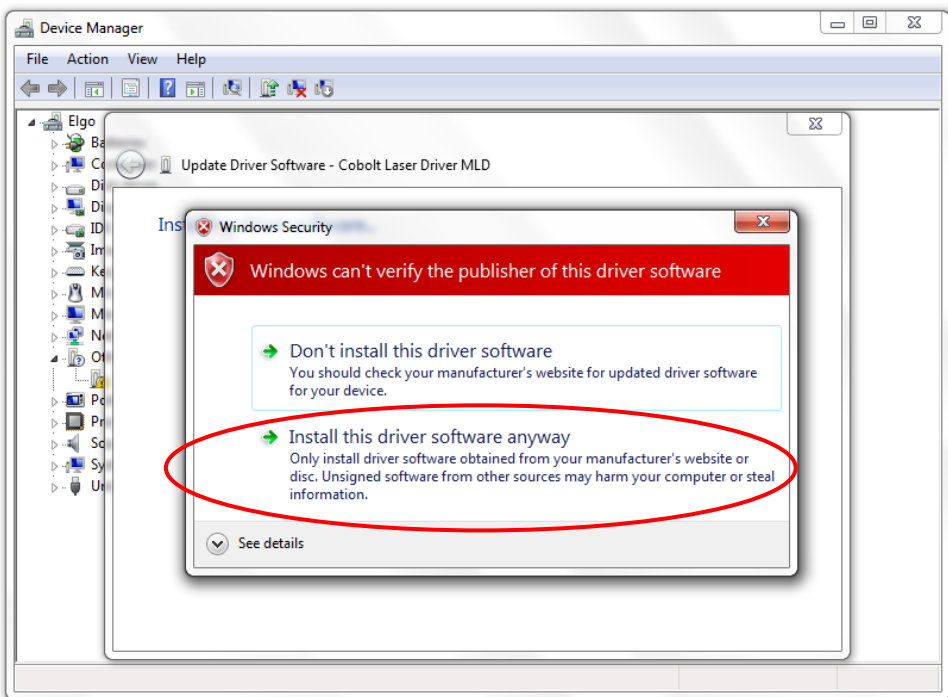

7. The installation should now be complete.

8. Cobolt Monitor™ Software

The Cobolt Monitor™ software provides a graphical way to monitor the laser performance and to change power, operation mode and other settings. The software can connect to the laser either via RS-232 or via USB, depending on the type of controller, please refer to Section 7.

Cobolt Monitor™ has been tested with operative systems Windows XP, Windows Vista, Windows 7, Windows 8 and Windows 10. Microsoft .NET 4.0 is required to run the Cobolt Monitor™ software. Most computers with operative systems Windows XP, Windows Vista, Windows 7, Windows 8 and Windows 10 have this included as standard.

8.1. Installation

Download the latest version of the Cobolt Monitor™ software from hubner-photonics.com. The Cobolt Monitor™ software is a stand-alone executable, the executable file is packaged with other files needed to run the program in a .zip file. Save the .zip file any storage device, and extract all files. The folder created after extracting the files can be placed on any storage device and Cobolt Monitor™ can be run from there. All files and folders contained in the .zip file must be present for the program to function properly.

8.2. Software instructions

The software automatically searches for Cobolt devices every 5 seconds and automatically connects the laser if detected. The software can identify USB connected lasers as well as RS-232 connected lasers.

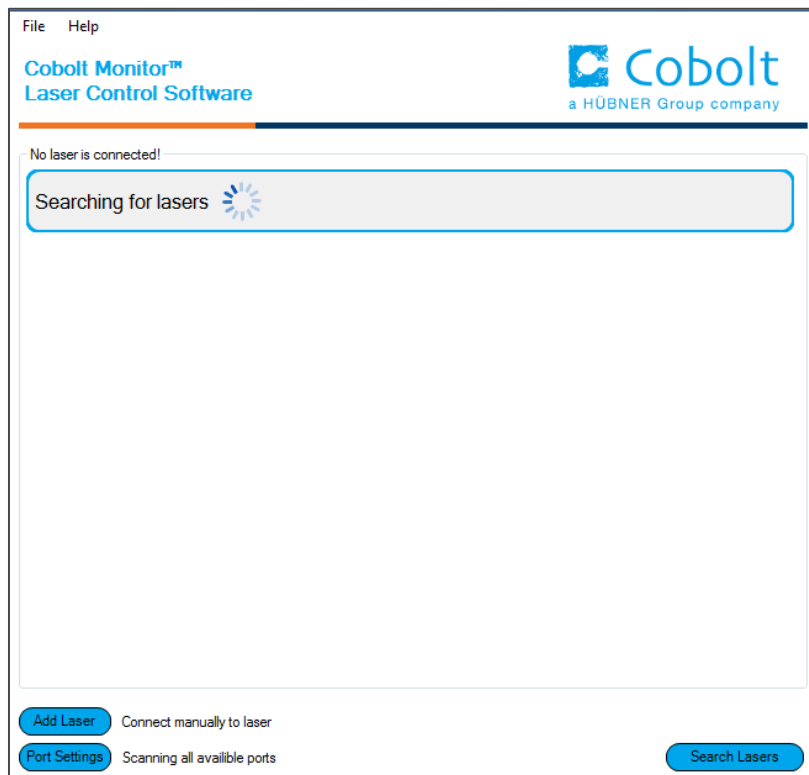

The first Cobolt Monitor™ window that appears in the Cobolt Monitor software.

Once the laser is connected it can be controlled from the box dedicated for the laser. The interface, found in the following figure, is intended for typical user cases. Only the relevant information is presented on this level, displaying

only the status the laser is in and relevant choices to make. Here follows a short description of how to use the Cobolt Monitor™ software on this level.

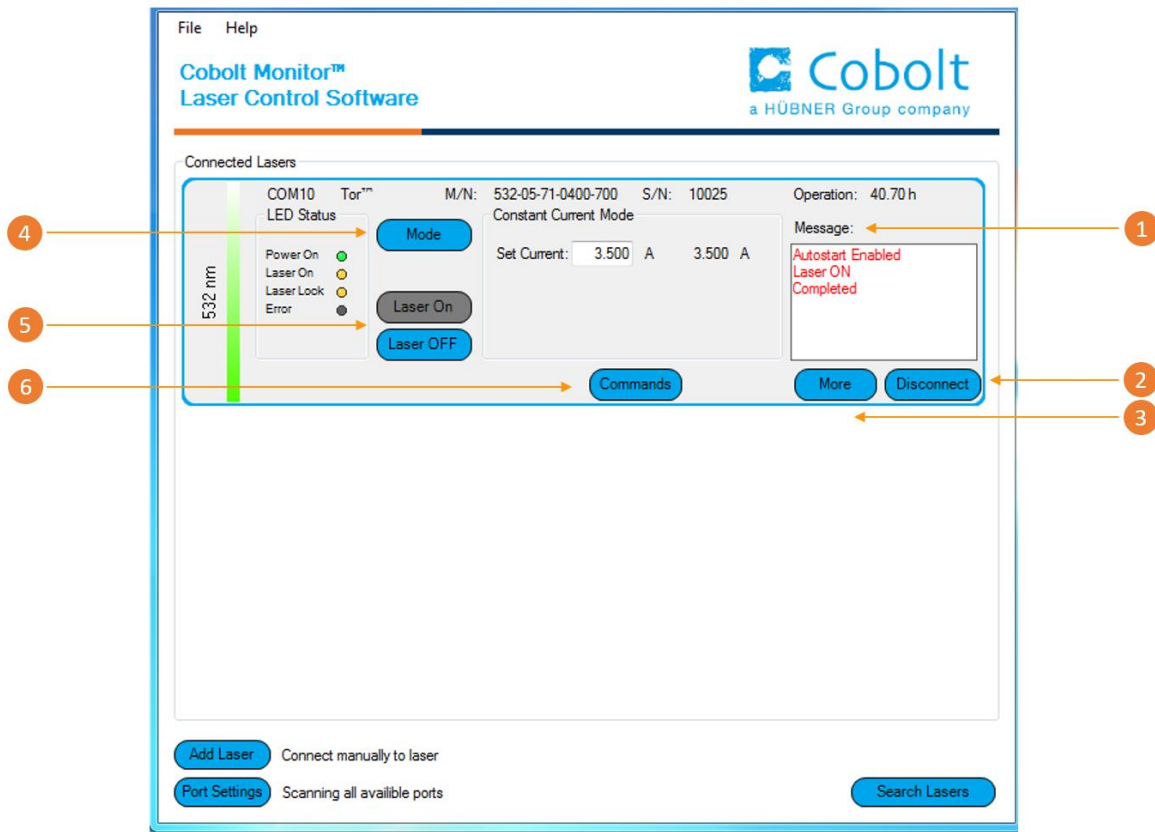

Cobolt Monitor™ software. Laser successfully connected.

- 1 **Message** – highlights important information of the laser status to the user.
 - 2 **Disconnect** – allows the user to disconnect from the software in a controlled way.
- ! Note:** The communication cable should not be removed when the software is in connect state. The communication within the controller may then malfunction and this might require a power restart of the driver. To disconnect the laser click “Disconnect” or close Cobolt Monitor™ completely. It is also possible to disconnect by powering the laser OFF. In this case Cobolt Monitor™ will automatically close the window for that laser.
- 3 **More** –an additional Cobolt Monitor™ window will open containing more detailed information of that laser’s status.
 - 4 **Laser ON** – Turns the laser ON. If the laser is in autostart mode this is equivalent to “restart”.
Laser OFF – Turns the laser OFF.

- 5 **Mode** – Gives a choice of operational modes possible to choose for the laser model. Cobolt Tor™ Series Constant Power, Constant Current, Burst Mode and Constant Repetition Rate (OEM only) operation can be chosen. Only relevant choices are presented to the mode of operation chosen. Only relevant choices are presented to the mode of operation chosen.
- 6 **Commands** – opens a command communications window to send commands directly to the laser controller.

Once **More** button is pressed the additional window as below will open.

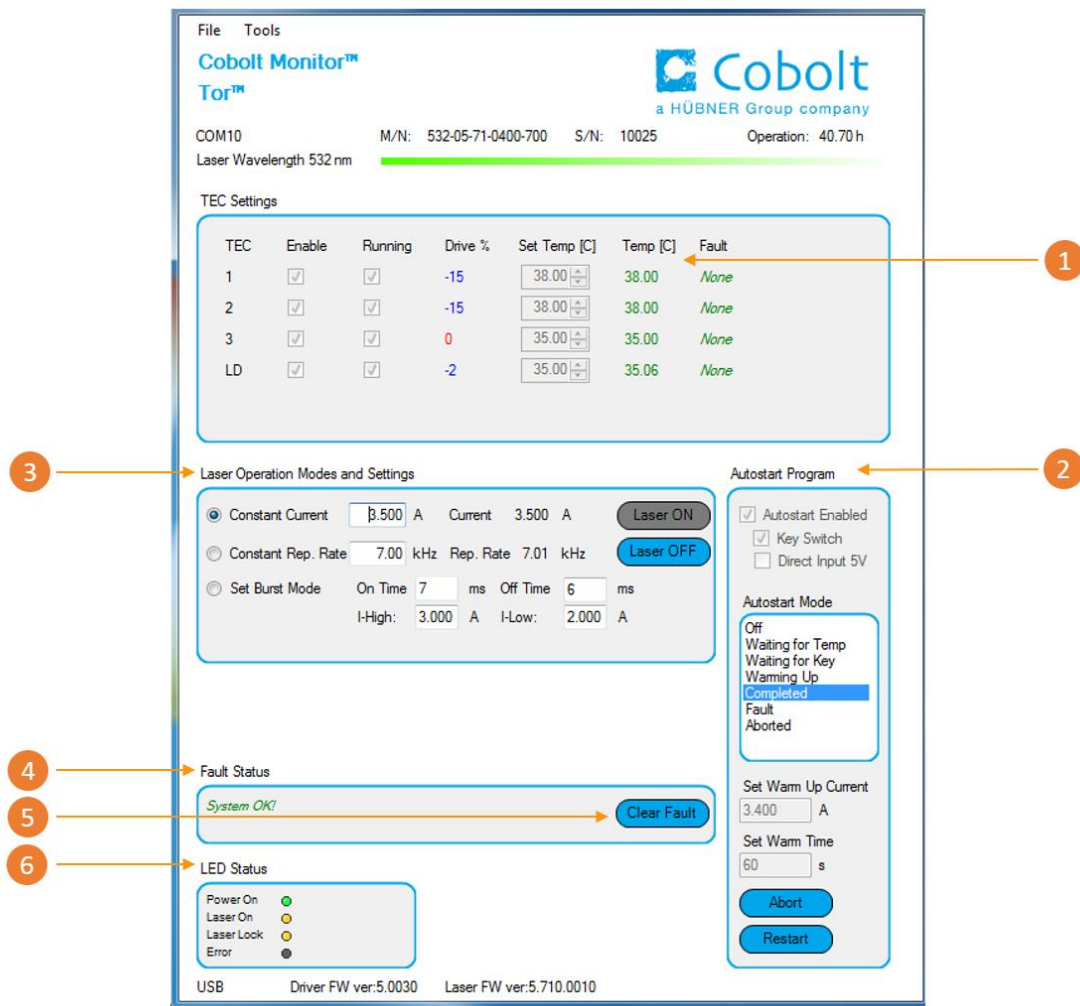

Cobolt Monitor™ software expanded to for more detailed monitoring.

- 1 **TEC Settings** – shows the running status and the fault status for the laser’s internal thermoelectric coolers (TEC).
 - 2 **Autostart Program** - displays whether the laser is in CDRH or OEM mode and displays the current laser operational status. 5 V direct input is set here, see section 4.4. There are also buttons to “abort” the autostart sequence or to “restart” the laser after a fault.
- ! Note** Specifications are only guaranteed in constant power mode, at 100 % of nominal power.

- 3 Laser Operation Mode and Settings** - displays the set laser power. The user can switch between operation modes. Likewise, there are boxes to set the current, burst mode, repetition rate levels. See section 0 for more information on operation modes.
- 4 Fault Status** – displays ERROR messages. In the event of an ERROR, the laser action is stopped. When the reason for the ERROR event is understood and the problem is addressed the fault status can be cleared with “Clear Fault”. If the Autostart Program is enabled, click restart to restart the laser
- 5 Clear Fault** - is displayed in the event of a fault. The user can deal with the cause of the fault and then press “Clear Fault” and then restart the laser by clicking “Laser ON”. Example: if the remote inter loop is open the user must make sure the loop is closed again before issuing a “Clear Fault” followed by “Laser On”.
- 6 LED Status** - displays the LEDs that are currently illuminated on the Controller, see Section 3.4. These are displayed even if the laser is in OEM mode.

9. Troubleshooting

In the unlikely case of a problem occurring, use the table below to help identify the error. The LEDs on the controller will be indicating the errors.

| LEDs | Status | Explanation | Action |
|-------|----------|-----------------------------|---|
| POW | OFF | Mains power off | Check connections |
| POW | Flashing | Temperatures not stabilized | Check if heatsink is sufficient |
| ERROR | ON | Error in laser parameters | If lights at start-up check cable connections, if lights >5 s after start-up contact the factory. |

Some faults can be fixed remotely. Back reflections into the laser cavity can cause instability. In case of a sudden voltage drop the laser will turn itself off and restart. If it is in CDRH configuration it will require that the key is turned on again. Contact Hübner Photonics or your local representative to identify corrective action.

10. Warranty and Maintenance

Cobolt provides a warranty of 12 months with unlimited number of operation hours. The laser systems are designed for modular repair or replacement in the event that the laser head or Controller malfunctions. Warranty is invalid if the laser system is operated outside of the specific limits and conditions as outlined in this document.

The Cobolt lasers are contained in sealed enclosures and should not be opened for any reason. Disassembly of any part of the system (including the cable) means the system no longer complies with the EMC standards will void the warranty. All laser parameters are set at the factory, and there are no adjustments required. Maintenance is limited to wiping dirt off the enclosures and cleaning the aperture.

11. Service

Due to accuracy tolerances, calibration differences and allowed power drift there may be discrepancies between the Cobolt measurement of the optical output power and the customer measurement equipment. If the output power deviates from the reported value please contact your local sales representative for an online re-calibration. If the laser does not function, do not attempt to open any of the units, or the warranty will be voided. Contact your local sales representative for consultancy and to request an RMA number (see back cover for contact information). If an RMA number is issued and the laser needs to be shipped back to Cobolt or your local representative, please pack the complete system for shipment using the original package or equivalent. Ensure the unit is free from thermal paste before packing. The warranty covers repair or replacing the unit at the option of the manufacturer.

12. Compliance (CDRH models only)

The CDRH model lasers (-5/700) are designed and manufactured to comply with the EC Low Voltage Directive and the EC EMC Directive in the CDRH-compliant configuration of laser head, 1 m controller cable, controller, key and power supply supplied by the manufacturer. All equipment must be mounted on a common ground plane, such as an optical table. If any part of the delivered equipment is replaced with a part not supplied by the manufacturer or if the equipment is not properly grounded, the system may not conform to CE / CDRH compliance standards listed in section 12. Disabling any of the safety features nullifies the CE marking and violates the laser safety standard.



The following harmonized and limits standards have been applied:

| | |
|---------------------------|---|
| Electrical Safety | EN 61010-1, IEC-61010-1, UL 61010-1 (Limited Energy System) UK S.I. 2016 No. 1101 : The Electrical Equipment (Safety) Regulations 2016 |
| Laser Safety/Class | IEC-60825-1 FDA / CDRH : Complies with 21 CFR 1040.10 and 1040.11 except for conformance with IEC 60825-1 Ed. 3., as described in Laser Notice No. 56, dated May 8, 2019. |
| EMC | IEC 61326-1 EN 55011 Electromagnetic Emission , Class A Electromagnetic Immunity – Table 1 Requirements EN 61000-4-2 Electrostatic Discharge ±4 kV contact discharge and ±2 kV, ±4 kV, ±8 kV air discharge EN 61000-4-3 Radiated electromagnetic fields 80 – 1000 MHz, 3 V/m with 80 % AM @ 1 kHz 1.4 – 2.7 GHz, 3 V/m with 80 % AM @ 1 kHz EN 61000-4-4 Fast transient / Burst AC Power input port ±2,0 kV EN 61000-4-5 Surge AC Power input port ±0,5 kV, ±1,0 kV, ±2,0 kV Com. Mode AC Power input port, ±0,5 kV, ±1,0 kV Diff. Mode EN 61000-4-6 Conducted Immunity 3 V with 80 % AM @ 1 kHz EN 61000-4-11 Dips and Interruptions 50 Hz and 60 Hz. Test voltages: 100 V and 230 V UK S.I. 2016 No. 1091 : Electromagnetic Compatibility Regulations 2016 FCC 47 CFR - Part 15 (2009): Subpart B, Class A |
| RoHS | EU Directive 2011/65/EU, EU 2015/863 and amendment EU 2017/2102 UK S.I. 2012 No. 3032 |

Contact your sales representative for a copy of the full Declaration of Conformity.

13. Disclaimer

Hübner Photonics will assume no responsibility for damage incurred by faulty customer equipment, such as measurement equipment, cables etc, used in conjunction with Cobolt lasers. Hübner Photonics makes no warranty of any kind with regard to the information contained in this guide, included but not limited to, implied warranties of merchantability and suitability for a particular purpose. Hübner Photonics shall not be liable for errors contained herein nor for incidental or consequential damages from the furnishing of this information. No part in this manual may be copied, reproduced, recorded, transmitted, or translated without the express written permission by Hübner Photonics.



Our Locations

Cobolt AB, a part of HÜBNER Photonics (Sales in Norway, Sweden, Finland and Denmark)

Solna, Sweden
Phone: +46 8 545 912 30
Fax: +46 8 545 912 31
E-mail: info.se@coboltlasers.com

HÜBNER Photonics GmbH (Sales in Germany, Switzerland and Austria)

Kassel, Germany
Phone: +49 561 994 060 - 0
Fax: +49 561 994 060 - 13
E-mail: info.de@hubner-photonics.com

HÜBNER Photonics Inc. (Sales in USA, Canada and Mexico)

San Jose, California, USA
Phone: +1 (408) 708 4351
Fax: +1 (408) 490 2774
E-mail: info.usa@hubner-photonics.com

HÜBNER Photonics UK (Sales in UK and Ireland)

Great Britain
Phone: +44 7359440871
E-mail: info.uk@hubner-photonics.com

www.hubner-photonics.com

HÜBNER Photonics

