

# Cobolt o8-01 Series

## Compact | Narrow linewidth lasers

405 nm	532 nm	785 nm
457 nm	561 nm	830 nm
473 nm	633 nm	1064 nm
488 nm	638 nm	
515 nm	660 nm	





# CONTENTS

<b>1.</b>	<b>Introduction</b>	<b>4</b>
<b>2.</b>	<b>Safety</b>	<b>5</b>
2.1.	General	5
2.2.	Beam Hazards	6
2.1.	Non-Beam Hazards	6
2.2.	Accessible emission information	7
2.3.	Fiber pigtailed and fiber coupled options	8
2.4.	Safety features	8
2.5.	Equipment Safety	9
2.6.	Warning and identification labels	10
<b>3.</b>	<b>Quick start guide for CDRH model</b>	<b>12</b>
3.1.	o8-DPL and o8-NLD(M) 785 nm	12
3.2.	o8-NLD	13
<b>4.</b>	<b>Overview</b>	<b>15</b>
4.1.	Model Number	15
4.2.	Configuration	15
4.3.	Laser head	16
4.4.	Model versions	16
4.5.	Key Control box	17
4.6.	Thermal management	17
4.7.	Power supply requirements	18
<b>5.</b>	<b>System description</b>	<b>19</b>
5.1.	Specifications	19
5.2.	Specifications – Fiber pigtailed option (o8-03)	22
5.3.	Specifications – Fiber coupled option (o8-X6 and o8-X7)	22
5.4.	Mechanical Drawings	23
5.5.	Remote Interlock Connector	27
5.6.	Direct On/Off control	28
5.7.	Pin assignment	29
<b>6.</b>	<b>Operation instructions</b>	<b>30</b>
6.1.	Start-up procedure	30
6.2.	Installation start-up operation	30
6.3.	Shutdown procedure operation	30
<b>7.</b>	<b>Operating modes</b>	<b>30</b>
<b>8.</b>	<b>Cobolt Monitor software</b>	<b>31</b>
8.1.	Installation	31
8.2.	Software instructions	31
<b>9.</b>	<b>Operation via data port</b>	<b>34</b>
9.1.	Data port connections	34
9.2.	Handshaking	34
9.3.	USB driver	34
9.4.	Communication commands	34
<b>10.</b>	<b>Troubleshooting</b>	<b>36</b>
<b>11.</b>	<b>Warranty and maintenance</b>	<b>37</b>
<b>12.</b>	<b>Service</b>	<b>37</b>
<b>13.</b>	<b>Disclaimers</b>	<b>37</b>
<b>14.</b>	<b>Compliance (CDRH models only)</b>	<b>38</b>

## 1. Introduction

The Cobolt o8-01 Series is a family of narrow linewidth continuous-wave lasers, including diode pumped lasers as well as frequency stabilized diode lasers operating at fixed wavelengths between 405 nm and 1064 nm with output power up to 500 mW. The lasers are designed and manufactured to ensure the highest level of reliability.

Cobolt lasers are built using proprietary HTCure™ manufacturing technology for ultra-robustness into a compact hermetically sealed package. The lasers emit a high-quality laser beam with very stable characteristics and reliable spectral performance, making them ideal for advanced analytical applications where stable and narrow spectral linewidth is crucial, such as Raman Spectroscopy and Interferometry.

Cobolt o8-NLD lasers are stabilized semiconductor diode laser modules with optional integrated optical isolators for optimal feedback immunity.

Cobolt o8-DPL lasers are diode pumped solid state lasers with optional integrated optical isolators for optimal feedback immunity.

The fiber pigtailed option for the Cobolt o8-01 Series is delivered with the fiber permanently aligned and fixed inside the sealed package using Cobolt's proprietary HTCure™ Technology, providing stable output over a large temperature range and insensitive to transport conditions.

The fiber coupled option for the Cobolt o8-01 Series is delivered with an external fiber coupler and fiber, available with either single-mode or multi-mode fibers. The external coupler is fastened directly onto the laser head. The coupling efficiency and stability are tested during manufacturing.

The Cobolt o8-01 Series are certified for use as stand-alone laboratory devices, but with a compact design and fully integrated drive and control electronics they are also very well suited but for integration as OEM components in analytical instrumentation.

## 2. Safety

### 2.1. General

Cobolt o8-DPL and o8-NLD lasers are Class IIIB (CDRH), Class 3B (IEC) laser products that emit less than 500 mW of laser radiation within the visible and near infrared (NIR) spectrum.



Cobolt o8-NLD(M) 785nm lasers are Class IV (CDRH), Class 4 (IEC) laser products that can emit more than 500 mW of invisible laser radiation at 785 nm (NIR).



#### Symbols in the manual



**WARNING – LASER RADIATION** This symbol is used to call attention to important laser safety information



**WARNING – STATIC MAGNETIC FIELD** This symbol is used to call attention to important magnetic field safety information



**CAUTION – GENERAL** This symbol is used to call attention to important general operator and equipment safety information



**NOTICE – GENERAL** This symbol is used to call attention to best practices when using the equipment and does not indicate a hazard.

## 2.2. Beam Hazards

Eye and skin exposure to direct or reflected laser light is hazardous and may be extremely harmful. Always wear eye protection appropriate to the beam wavelength and intensity. Lasers may pose a risk of igniting flammable materials and in event of ignition gasses and fumes may be generated. All equipment used in close proximity to the laser beam should be suitably fire resistant and the facility should be properly ventilated. It is advised to perform a risk assessment for the facility and equipment prior to using the laser. In the case of integration into a larger system, laser safety compliance must be evaluated in the end product.



**WARNING** Remove all watches, rings and other reflective jewelry before working with lasers. Always wear the appropriate eye protection from the wavelengths integrated into the system. As the system can be integrated with different laser lines after delivery, verify the accessible emission wavelength and power before operating. **Never look directly into a laser beam.**

The device must be handled by skilled personnel experienced with lasers, in a laboratory environment and with access to adequate laser safety equipment. The laser head clearly displays a yellow warning label that shows the location of the laser beam aperture. This label must be visible unless the laser beam is totally enclosed. If the laser does not function, do not attempt to open any part of the device, or the warranty will be voided. Call or e-mail your local Cobolt representative for consultancy and to request an RMA number (see back cover for contact information).

Laser radiation may ignite flammable materials and combustible gasses in the beam path and, in event of ignition, fumes may be generated. All equipment used in close proximity to the laser beam should be suitably fire resistant and the facility should be properly ventilated.



**CAUTION** Use of controls or adjustments or performance of any procedures other than those specified herein may result in exposure to hazardous radiation.

## 2.1. Non-Beam Hazards

### Strong Internal Magnet

Laser heads with optical isolators (Cobolt model o8-1X) contain strong permanent magnets. Proceed with caution when positioning or servicing the laser near material which may be magnetized and when operating with tools which may be magnetized (e.g. screwdriver) around the laser head. Users with implanted medical devices should stay back at least 30cm (12 inches).



### 2.2. Accessible emission information

The table below describes the irradiance in W/cm<sup>2</sup> and appropriate level of eye protection in terms of optical density (OD) for each product line.

Product	Laser Class	Nominal Output Power (mW)	Irradiance (W/cm <sup>2</sup> )	Eye protection Requirement
Cobolt o8-NLD 405 nm	3B	40	16	> OD 4
Cobolt o8-DPL 457 nm	3B	30	11	> OD 4
Cobolt o8-DPL 473 nm	3B	50	18	> OD 4
Cobolt o8-NLD 488 nm	3B	40	16	> OD 3
Cobolt o8-DPL 515 nm	3B	50	18	> OD 3
Cobolt o8-DPL 532 nm	3B	200	71	> OD 3
Cobolt o8-DPL 561 nm	3B	100	35	> OD 3
Cobolt o8-NLD 633 nm	3B	30	12	> OD 3
Cobolt o8-NLD 638 nm	3B	80	31	> OD 3
Cobolt o8-DPL 660 nm	3B	50	19	> OD 3
Cobolt o8-NLD 785 nm	3B	120	47	> OD 3
Cobolt o8-NLD(M) ESP 785 nm	3B	400	39	> OD 3
Cobolt o8-NLD(M) 785 nm	4	500	49	> OD 4
Cobolt o8-NLD 830 nm	3B	100	39	> OD 3
Cobolt o8-DPL 1064 nm	3B	400	69	> OD 3

The equations below describe how to use the nominal output power (mW) and beam area to calculate the irradiance (W/cm<sup>2</sup>) and how to use the Warning label (Max) power (mW) and the Accessible Emission Limit (AEL) (mW) per laser safety standard IEC 60825-1:2014 to calculate the required optical density (OD) for eye protection per wavelength.

$$\text{Irradiance} \left( \frac{\text{W}}{\text{cm}^2} \right) = \frac{110 \% \text{ of Nominal Laser Power (mW)}}{\text{Beam area at bottom tolerance (cm}^2\text{)}}$$

$$\text{Require Attenuation of Laser Safety Glasses (OD)} = \log_{10} \left\{ \frac{\text{Warning Label Power (mW)}}{60825 - 1 \text{ Laser Class 1 AEL (mW)}} \right\}$$



**WARNING** Always wear the appropriate eye protection for all of the specified emitted wavelengths. Verify the accessible emission wavelengths and power levels on the warning label before operating.

### 2.3. Fiber pigtailed and fiber coupled options

All safety recommendations in section 2.1 are also valid for the Cobolt o8-01 Series fiber coupled laser heads. Additionally, heat generated from absorption of laser radiation by particles on the fiber end may increase the probability of ignition hazards in certain environments. Always clean the fiber end before turning on the laser. In systems where the beam is exposed, fiber end must be mounted <2m from the emission warning LED. It is advised to perform a risk assessment for the facility and equipment prior to using the laser. In the case of integration into a larger system, laser safety compliance must be evaluated in the end product.

### 2.4. Safety features

The laser is equipped with all required safety features as described in the laser safety standard IEC 60825-1:2014. If any part of the delivered equipment is replaced with a part not supplied by Cobolt or if the equipment is not properly grounded the device may not conform to CE / CDRH compliance standards listed in section 14. Disabling any of the safety features nullifies the CE marking and violates the laser safety standard.

#### **Remote Interlock Connector**

The remote interlock connector is a connector which permits the connection of external controls placed apart from other components of the laser product. When the terminals of the connector are open-circuited, the accessible radiation shall not exceed laser Class 1. The remote interlock connector permits easy addition of an external interlock in laser installation. See section 0 for a detailed description of the remote interlock circuit and operation.

#### **Beam Stop (Manual Shutter)**

The laser head is equipped with a manual shutter, which functions as the beam stop, capable of preventing human access to laser radiation. The aperture location and the open and close positions of the shutter are indicated on the top surface of the laser head.

#### **Key Control**

The CDRH compliant model comes with a key control box which must be connected for the laser to operate. When the key is in the OFF position, the diode is prevented from emitting. The key must be actively turned to the ON position each time the laser is powered on. When the key is removed from the system laser radiation is not accessible.

#### **Laser Radiation Emission Warning**

The key control box, which is part of the CDRH compliant models, incorporates LEDs which indicate the status of the Laser. The "ON" LED is illuminated whenever the device is emitting or could emit light. See section 4.5 for details on the key control box. The emission warning indicators are also visible in the control software GUI, see section 8 for details on the control software.



## 2.5. Equipment Safety

### **Back Reflection Sensitivity**

Laser light reflected directly back into the laser head causes damage to the laser diode and results in a dramatic decrease in product lifetime.

### **Electrostatic discharge**

Always install the laser system to a properly grounded power outlet. Cobolt o8-NLD lasers contain a laser diode which is sensitive to electrostatic discharge (ESD).

### **Fiber care**

It is important to always make sure the fiber end-face is clean before turning the laser on and before connecting the fiber connector in physical contact with another connector. Failure to do so may lead to irreparable damage of the fiber end-face. Do not clean the fiber when the laser is on. We recommend using appropriate equipment for fiber cleaning and inspection.

## 2.6. Warning and identification labels

The upper face of the laser head contains a yellow label with laser safety warning and classification information, the wavelength and maximum power of the unit. It also shows the location of the laser beam from the aperture and indicates the open and close positions of the manual shutter. This label must be visible unless the laser beam is totally enclosed. A silver label showing information about the laser model, manufacturer date and location, and the power supply voltage and current, is located on the laser head. Lasers shipped to customers in the USA also contain a label of CDRH compliance.

### 2.6.1. Stick placement for : o8-01, o8-03, o8-51, o8-07, o8-57

#### Manufacturer Identification Labels

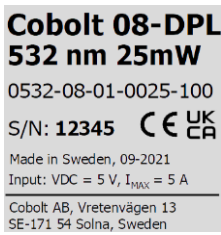

CE marking for CDRH models only

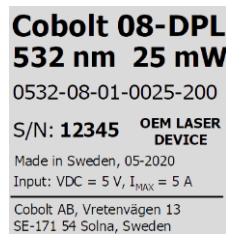

OEM Label



Aperture Warning Label

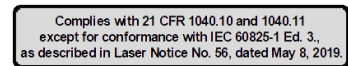
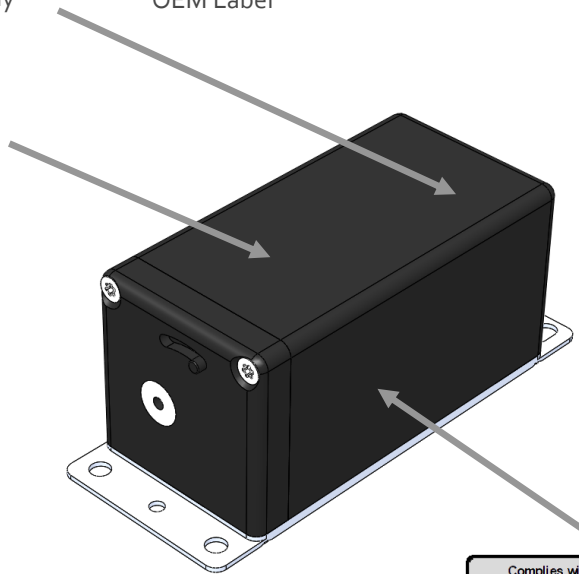

Laser Notice No. 56 Label

CDRH models shipped to USA

2.6.2. o8-1X, o8-2X

Manufacturer Identification Labels

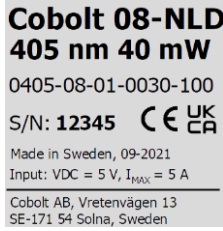

CE marking for CDRH models only

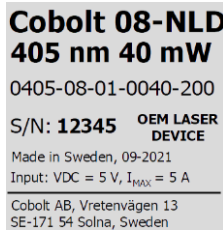

OEM Label



Aperture Warning Label

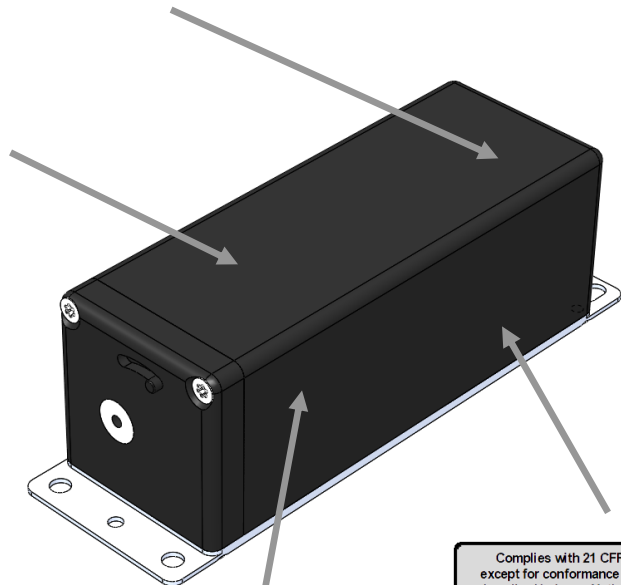

Complies with 21 CFR 1040.10 and 1040.11 except for conformance with IEC 60825-1 Ed. 3., as described in Laser Notice No. 56, dated May 8, 2019.

Laser Notice No. 56 Label

CDRH models shipped to USA



Magnetic field warning label

### 3. Quick start guide for CDRH model

#### 3.1. o8-DPL and o8-NLD(M) 785 nm

1. Mount the laser on a heat sink or suitable flat surface that provides adequate heat dissipation and connection to ground. Use the four holes on the laser's base plate to secure it.



2. Attach the 6-pin Molex cable to the laser head. Be sure the orange arrow is facing the top (labelled) side of the laser head.



3. Attach the 15-pin D-SUB cable to the control box.



4. Insert the remote interlock plug into the connector on the control box.



5. Connect the supplied 5 V power supply unit to the socket on the laser head, and plug it in to the mains.



6. To start the laser, turn the key on the control box clockwise to the ON position. If it is already in the ON position, turn it to OFF and then ON again. Light will be emitted when the TECs have stabilized. Once the key is turned it can take a few seconds for the TECs to reach their set temperature, at which time the laser will begin to emit without further action from the user.



### 3.2. o8-NLD

1. Mount the laser on a heat sink or suitable flat surface that provides adequate heat dissipation and connection to ground. Use the four holes on the laser's base plate to secure it.



2. Attach the 15-pin D-SUB cable to the laser head.



3. Attach the 15-pin D-SUB cable to the Control Box.



4. Insert the interlock plug into the connector on the laser head.



5. Connect the supplied 5V power supply unit to the socket on the laser head, and plug it in to the mains.



6. To start the laser, turn the key on the Control Box clockwise to the ON position. If it is already in the ON position, turn it to OFF and then ON again. Light will be emitted as soon as the key is turned.



7. The laser will now start up in continuous-wave, constant current mode at its nominal maximum power level. The power and wavelength may continue to drift for up to 3 minutes while the temperature of the platform stabilizes.



**NOTICE** If the power does not match the power as stated on the test sheet see Section 12 : Service , for more information.

## 4. Overview

### 4.1. Model Number

The Cobolt o8-01 Series lasers are sold in two configurations: CDRH and OEM, described in section 4.2. The model numbers are composed as described below.

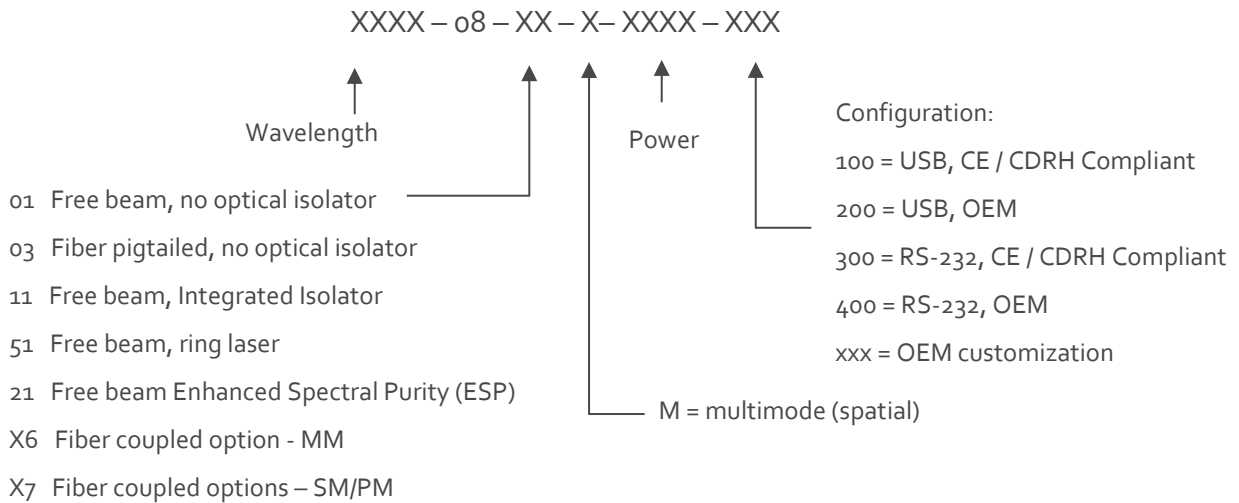

### 4.2. Configuration

#### CE / CDRH – for stand-alone operation

The laser is supplied with a key control box, which must be connected, along with a remote interlock connector. Once power is supplied, laser emission starts when the key is turned from the OFF position to the ON position. The status of operation can be monitored via LEDs on the control box. Setting the key to its OFF position puts the laser in stand-by mode. **The CE / CDRH model is CE and CDRH compliant.**

The CE/CDRH model consists of:

- Laser head
- 5 V power supply unit
- USB or RS-232 communication cable
- Remote interlock mono plug (for short circuiting the remote interlock connector)
- Key control box
- Keys
- For NLDs: 15-pin D-SUB male-male cable between the laser head and key control box
- For DPLs and NLD(M) : 6-pin Molex to 15 pin Sub-D cable between laser head and key control box

#### OEM – for integration only

The laser head is supplied without the key control box. Connecting a 5 VDC power supply to the laser head initiates an automatic start-up sequence. If the remote interlock is connected, laser emission will start automatically as soon as power is supplied and internal temperatures are stabilized.

The OEM model consists of:

- Laser head
- 5 V power supply unit
- USB or RS-232 communication cable
- Remote interlock plug (for short circuiting the remote interlock connector)

### 4.3. Laser head

The laser head features a manual mechanical shutter as well as a laser hazard label and a laser classification label, remote interlock and key control box connections. The mini-USB is used to communicate with the laser. The laser assembly is also equipped with on-platform elements for temperature control of the laser diode, and the system contains an optical feed-back loop which measures the power of the emitted beam. The control electronics boards are integrated into the laser head assembly. All versions covered in this manual are available with both CE/CDRH compliant and OEM configurations. See section 5.7 for further information about connectors and pin out specifications. Typically, all lasers will be disturbed by reflected light re-entering the laser cavity. Most o8-01 series lasers can be configured with an integrated optical isolator, see section 5.1 for more information. Optical isolator reduces the amount of light re-entering the laser cavity and is recommended when working with reflective samples.

#### Cobolt o8-DPL

The laser head contains a diode pumped laser, non-linear optics for frequency conversion, integrated spectral filter, beam collimation optics, a thermoelectric cooler (TEC), and integrated control electronics boards.

#### Cobolt o8-NLD

The laser head contains a frequency stabilized diode laser, integrated spectral filter, beam collimation optics, a thermoelectric cooler (TEC), and integrated control electronics boards.

### 4.4. Model versions

#### Version o8-01 and o8-51

Cobolt o8-01 and o8-51 are free beam lasers, without optical isolator. For better feedback immunity choose version o8-11 with integrated optical isolator. The laser head version o8-51 cavity design has an intrinsically higher immunity to back reflections compared to the o8-01 and is not available with an integrated isolator.

#### Version o8-03

Cobolt version o8-03 lasers are delivered with a permanently aligned fiber pigtail. The fiber is equipped with a removable end cover for protection of the fiber end facet. The fiber end cover also serves as the mechanical shutter of the laser system. Cobolt o8-NLD 785 nm, Cobolt o8-DPL 532 nm and Cobolt o8-DPL 561 nm are available in version o8-03.

#### Version o8-11 / o8-21

In addition to all features of the standard laser head, the o8-11 and o8-21 laser heads contain an optical isolator.





**Version o8-16 / o8-26 / o8-17**

Fiber coupled laser head with integrated optical isolator.



**Version o8-07 / o8-57**

Fiber coupled laser head without integrated optical isolator (not shown).

**4.5. Key Control box**

The key control box allows the user to operate the laser with a CDRH-compliant key-switch. The control box has LEDs to indicate the laser status. When power is supplied to the laser head, regardless of on/off or key-switch state, the temperature control element will be active to reach its set point values.

The status of the laser operation is given via LED indicators:

- ON**            Orange    Laser emission is on.
- ERROR**    Red        An error has occurred.



**4.6. Thermal management**

To ensure operation within given specifications and for the warranty to be valid, the laser head must be mounted on a heat sink. The requirement on thermal resistance of the heat sink can be calculated by taking the difference between the maximum allowed laser head base plate temperature and the ambient temperature at the air-heat sink interface (40 °C), divided by the maximum power dissipated from the laser. This relationship is used to determine the required heat sink thermal resistance for operation at 40 °C ambient temperature at the air-heat sink interface. See the table below for the heat sink requirement and laser head heat dissipation for each product.

Product	Maximum baseplate Temp. (°C)	Heat Sink thermal impedance (K/W)	Heat Dissipation (W)
o8-DPL (all)	50	0.5	20
o8-NLD	50	0.8	12
o8-NLD(M) 785 nm	55	1.0	15

The mounting surface should be flat within 0.05 mm over the mounting surface. Under normal circumstances thermal heat compound is not required, however if the laser is operated in an area with a high ambient temperature it is recommended to use a compound between the laser head and the heat sink to provide good thermal contact. For assistance in thermal management and system integration, please contact Cobolt’s technical support.

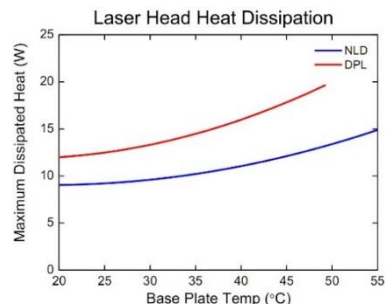
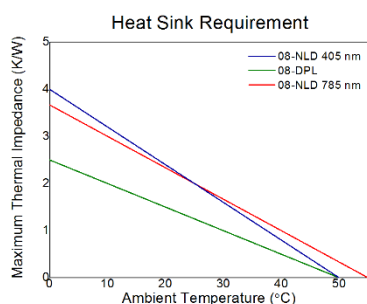

#### 4.7. Power supply requirements

An appropriate Power Supply Unit (PSU) is supplied by Cobolt with the laser and can be plugged into a standard power outlet. The power supply accepts 100-240 VAC and 47-63 Hz. Ripple and noise 2.4 % peak-peak max, 20 MHz bandwidth. Accepted voltage range for the laser head is  $5.0 \pm 0.2$  VDC. Specification values are given at 5 VDC. The output from the Cobolt supplied PSU is 5 VDC. The maximum current is 5 A (max 25 W), though for o8-NLD and o8-NLD(M) lasers 3 A is sufficient.

## 5. System description

### 5.1. Specifications

The information presented here is believed to be accurate and is subject to change without notice. The specifications contained herein cannot be guaranteed outside of normal operational conditions. The output power can be adjusted using control commands, see Section o. Specifications are guaranteed at 100% of nominal power. The wavelength for each unit is fixed at a value within the stated range. The wavelength is measured in air.

#### 5.1.1. Wavelength and Power

Product	Wavelength (nm)	Max. available Power (mW)		Max. Optical Feedback (%)	
		without isolator	[with isolator]	without isolator	[with isolator]
o8-NLD 405	405.0 ± 0.5	40	[30]	1 %	[ 100 %]
o8-DPL 457	457.0 ± 0.3	30	[25]	1 %	[ 100 %]
o8-DPL 473	473.0 ± 0.3	50	[40]	1 %	[ 100 %]
o8-NLD 488	488.0 ± 0.5	40	[n/a]	1 %	[ n/a]
o8-DPL 515	514.4 ± 0.3	50	[50]	1 %	[ 100 %]
o8-DPL 532	532.1 ± 0.3	200	[160]	10 %	[ 100 %]
o8-DPL 561	561.2 ± 0.3	100	[n/a]	1 %	[ n/a]
o8-NLD 633	632.8 ± 0.5	n/a	[30]	n/a	[ 100 %]
o8-NLD 638	638.0 ± 0.5	n/a	[80]	n/a	[ 100 %]
o8-DPL 660	659.6 ± 0.3	50	[50]	1 %	[ 100 %]
o8-NLD 785	784.8 ± 0.5	n/a	[120]	n/a	[ 100 %]
o8-NLD(M) 785	784.8 ± 0.5	n/a	[500]	n/a	[ 100 %]
o8-NLD(M) ESP 785	784.8 ± 0.5	n/a	[400]	n/a	[ 100 %]
o8-NLD 830	830. ± 0.5	100	[n/a]	1 %	[ n/a]
o8-DPL 1064	1064.2 ± 0.6	400	[n/a]	10 %	[ n/a]

5.1.2. Optical properties o8-DPL

	457 nm	473 nm	515 nm	532 nm	561 nm	660 nm	1064 nm
Spectral bandwidth (FWHM)	< 1 MHz						
Spectral Purity @ ± > 0.5 nm from main peak	> 60 dB						
@ ± > 5.0 nm from main peak	> 80 dB						
Wavl. Stability (± 3° C, 8 hrs)	± 1 pm						
Divergence, full angle	< 1.2 mrad					< 1.5	< 1.8
Spatial mode	TEM <sub>00</sub> , M <sup>2</sup> < 1.1					< 1.3	
Beam symmetry	> 0.95:1						
Beam diameter at aperture	700 ± 70 μm					1000 ± 100 μm	
Noise 250 Hz - 2 MHz (rms)	< 0.25 %						
Power stability (8 hrs, ± 3° C)	< 2 %						
Polarization extinction ratio	> 100:1, vertical						
Ambient temp. & pointing	< 5 μrad / °C (20-50 °C)						
Beam position accuracy	< 0.25 mm						
Beam angle accuracy	< 5 mrad						

5.1.3. Optical properties o8-NLD

	NLD						NLD(M)	NLD(M) ESP
	405 nm	488 nm	633 nm	638 nm	785 nm	830 nm	785 nm	
Spectral bandwidth (FWHM)	< 1 pm						< 100 pm	< 70 pm
Spectral Purity @ ± > 0.5 nm from main peak	> 40 dB						> 40 dB	> 60 dB
@ ± > 5.0 nm from main peak	> 80 dB						> 80 dB	> 80 dB
Wavl. Stability (± 3° C, 8 hrs)	± 1 pm						n/a	
Divergence, full angle, mrad	< 1.2	< 1.3	< 1.6		< 2.0	< 2.3	Horizontal : < 15 Vertical : < 3	
Spatial mode	TEM <sub>00</sub> , M <sup>2</sup> < 1.3						Multimode	
Beam symmetry	> 0.90 :1						n/a	
Beam diameter at aperture	700 μm ± 100 μm						H: 1.4 ± 0.2 mm V: 1.7 ± 0.2 mm	H: 1.6 ± 0.3 mm V: 1.2 ± 0.2 mm
Noise 250 Hz - 2 MHz (rms)	< 0.2 %						< 0.25 %	
Power stability (8 hrs, ± 3° C)	< 2 %						< 1 %	
Polarization extinction ratio	> 100:1, vertical							
Ambient temp. & pointing	< 10 μrad / °C (20-50 °C)						---	
Beam position accuracy	< 0.5 mm							
Beam angle accuracy	< 5 mrad							

5.1.4. Operational and environmental requirements

Product	o8-NLD	o8-DPL	o8-NLD(M) 785
Intended use environment	Laboratory		
Pollution Degree	2		
Operating temperature	10°C – 40°C		
Storage temperature	-10 to +60 °C		
Humidity @ 25°C	0 – 90 % RH, non-condensing		
Ambient Air pressure	950-1050 mbar		
Maximum baseplate temperature	50 °C		55 °C
Maximum heat dissipation of laser head	< 12 W	< 20 W	< 15 W
Laser head heat sink thermal impedance @ 40 °C ambient temperature	< 0.8 K/W	< 0.5 K/W	< 1 K/W
Warm-up time from complete “off”	< 3 min		
Power supply requirements	5 VDC, 3 A	5 VDC, 5 A	5 VDC, 3 A
Communication protocol	USB or RS-232		

5.1.1. Mechanical properties

Product model	o8-01	o8-51	o8-03	o8-11	o8-21	o8-16	o8-26	o8-17	o8-07	o8-57
Laser head dimensions	100 x 40 x 40 mm			128 x 40 x 40 mm		136 x 43 x 40 mm			108 x 43 x 40 mm	
Laser head weight	< 0.3 kg					< 0.5 kg				
Key box dimensions	42 x 56.6 x 32									

5.1.2. Electrical interfaces

All equipment connected to the system should be limited energy as described by IEC 61010:1.

Interface	Location	Connector type	
		o8-NLD	o8-DPL and o8-NLD(M) 785
Input power	Laser head	DC plug 2.5 mm / 5.5 mm female	
Remote interlock, OEM	Laser head	2.5 mm TRS audio female	6-pin Molex 90130-3206 (pin 1 & 2).
Remote interlock, CDRH	Laser head		---
Data port	Laser head	USB-type mini B	
Key control box	Laser head	VGA D-SUB 15-pin	6-pin Molex 90130-3206
Direct ON/OFF (OEM Only)	Laser head	---	6-pin Molex 90130-3206 (pin 5 & 2)
<i>Not used</i>	Laser head	SMA	---
Laser Head	Key control box	VGA D-SUB 15-pin	VGA D-SUB 15-pin
Remote interlock, CDRH	Key control box	---	3.5 mm TRS audio female
Direct Input 5V	Key control box	3.5 mm TRS audio female	---
RS-232 communication	Key control box	D-SUB 9-pin	

5.2. Specifications – Fiber pigtailed option (o8-03)

Product	o8-DPL 532 nm	o8-DPL 561 nm	o8-NLD 785 nm	o8-NLD(M) 785 nm
Available Power (mW) - Out of fiber	100 mW	50 mW	60 mW	400 mW
Power stability (8 hrs ± 3°C)	3 %			
Mode field diameter (MFD)*	4.0 ± 0.5 μm		4.5 ± 0.5 μm	n/a
Fiber core diameter	n/a		n/a n/a	105 μm
Fiber Output	FC/APC, Narrow key			FC/PC, Narrow key
Fiber Type	SM/PM			MM
Fiber end cap	No			
Polarization	PER > 100:1, ± 2°			n/a
Standard Fiber Length	1 m			
Jacketing	Ø 3mm, Stainless Steel			
Warranty	Laser warranty and 12 months on workmanship			

\* MFD is measured at the nominal wavelength for the fiber, 480 nm and 630 nm respectively.

5.3. Specifications – Fiber coupled option (o8-X6 and o8-X7)

5.3.1. Optical Specifications Fiber coupled lasers – Single mode

Product	405 – 660 nm*	785 nm	1064 nm
Coupling Efficiency	> 50 %		
Mode field diameter (MFD)	3.5 @ 405 nm - 7.5 @ 660 nm	6.4	10.6
Fiber Output	FC/APC, Narrow key		
Fiber Type	SM/PM		
Fiber end cap	Yes	No	
Fiber length	2 m		
Jacketing	PVC		
Warranty	Laser warranty and 12 months on workmanship		

\* Not including 488m

5.3.1. Optical Specifications Fiber coupled lasers - Multimode

Product	o8-DPL 532 nm	o8-NLD(M) 785 nm
Coupling Efficiency	> 60 %	> 70 %
Fiber core diameter	105 μm	
Fiber Output	FC / PC, Narrow key	
Fiber Type	Multimode	
Fiber length	2 m	
Jacketing	PVC	
Warranty	Laser warranty and 12 months on workmanship	

### 5.4. Mechanical Drawings

Mechanical drawings of the laser head and control box, showing dimensions (in mm) and connectors, are shown below.

#### Laser head o8-01 and o8-51

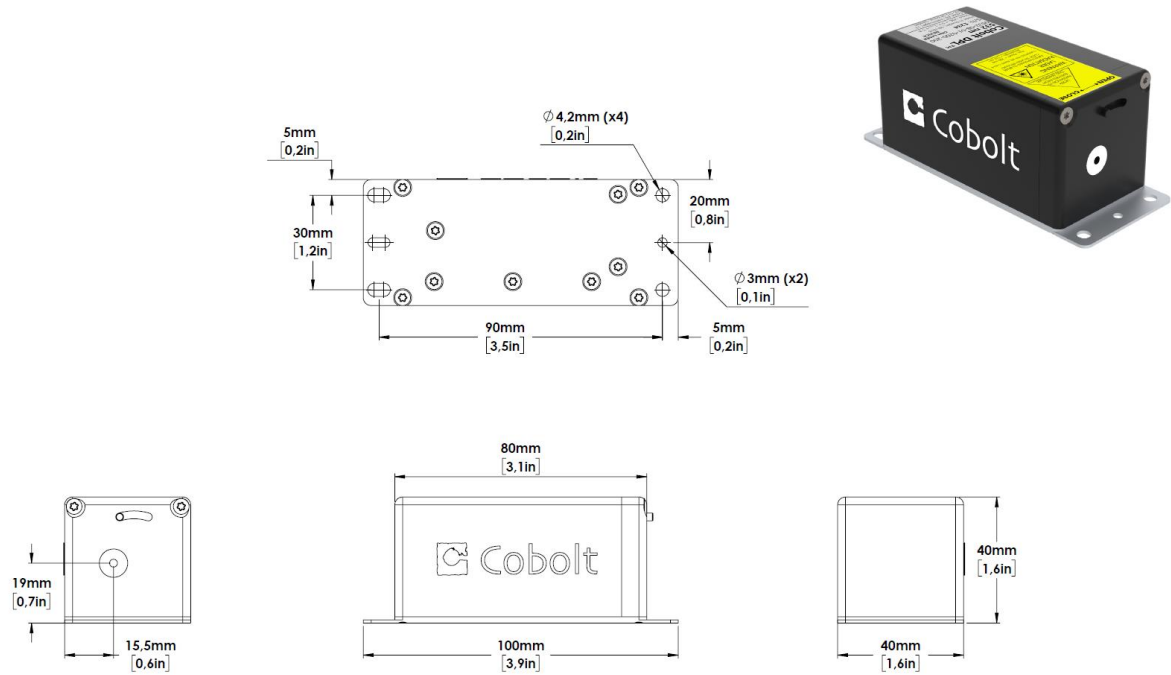

#### Laser head o8-11 and o8-21

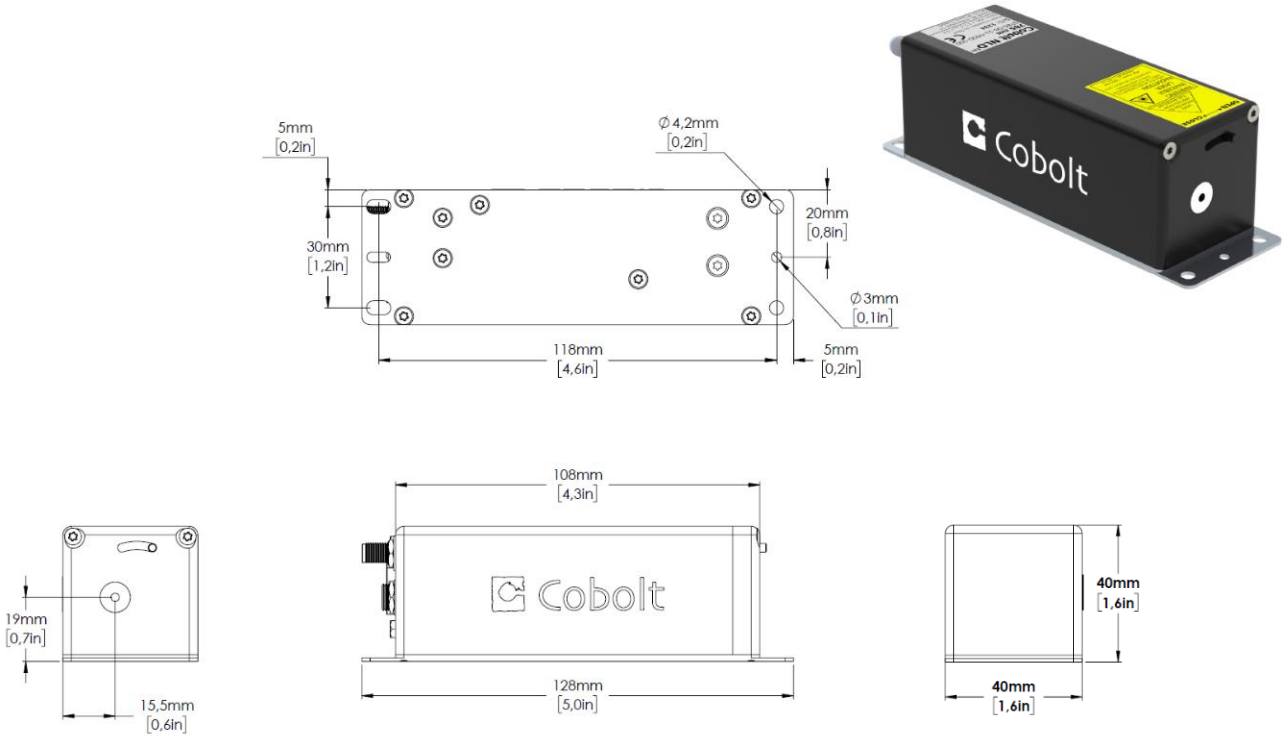

Laser head o8-o3

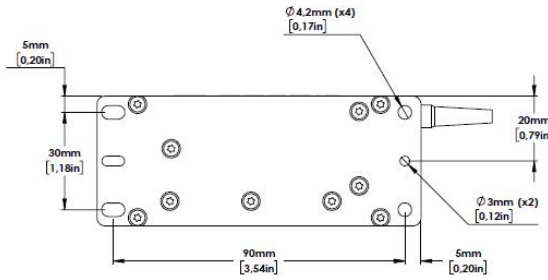

o8-DPL and o8-NLD(M)

o8-NLD

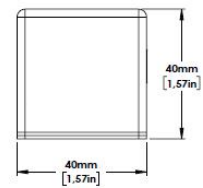
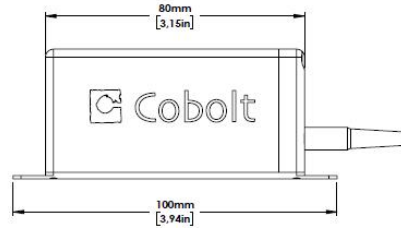
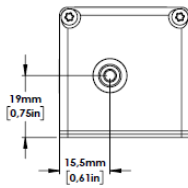
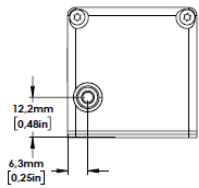

Laser head o8-17

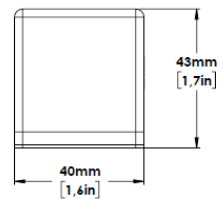
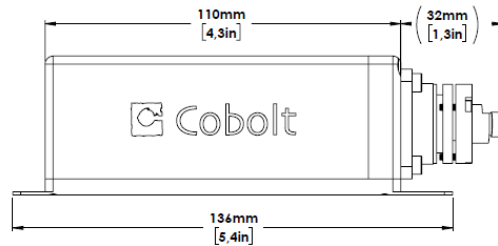
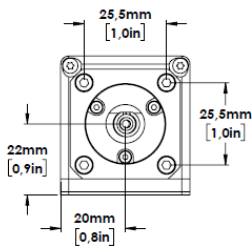
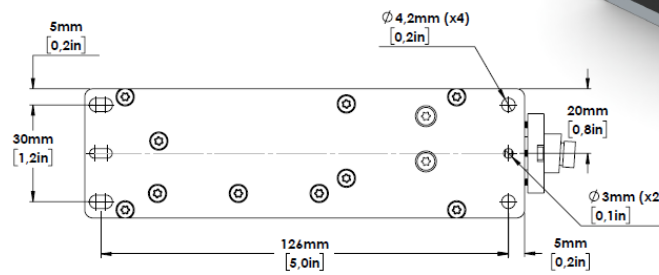



Laser head o8-07 and o8-57

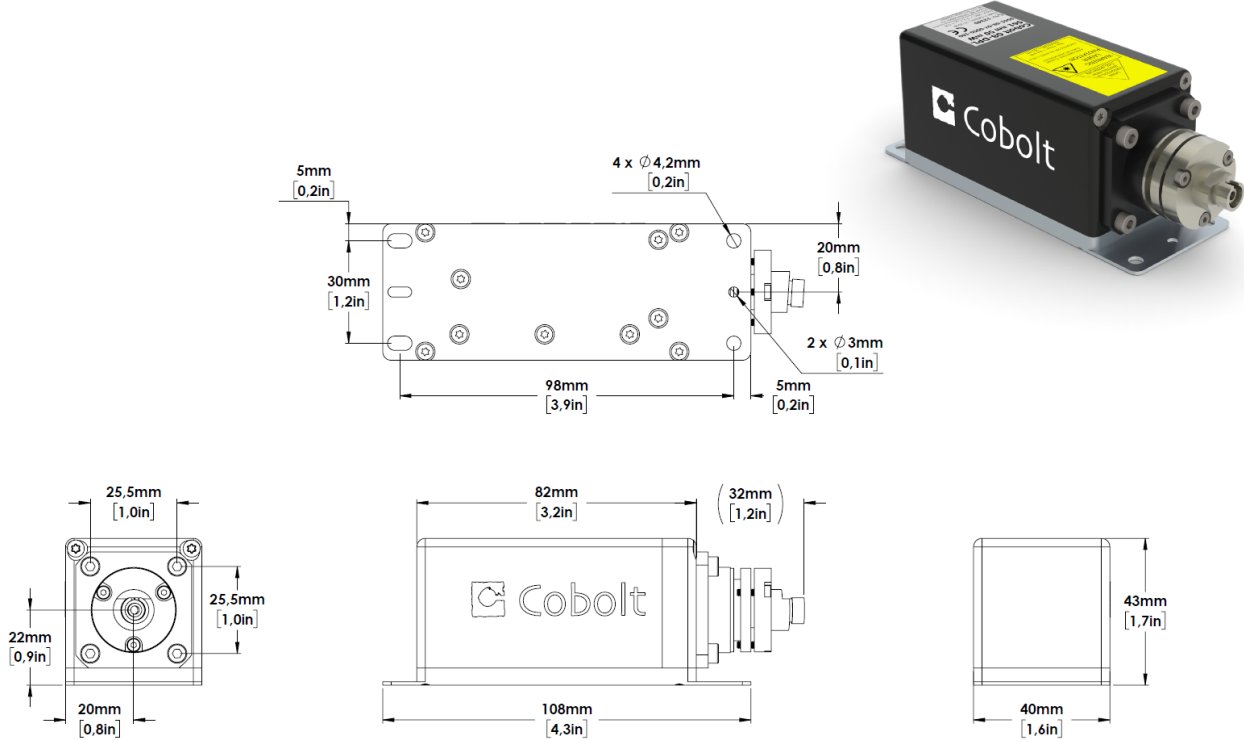

Laser head o8-16 and o8-26

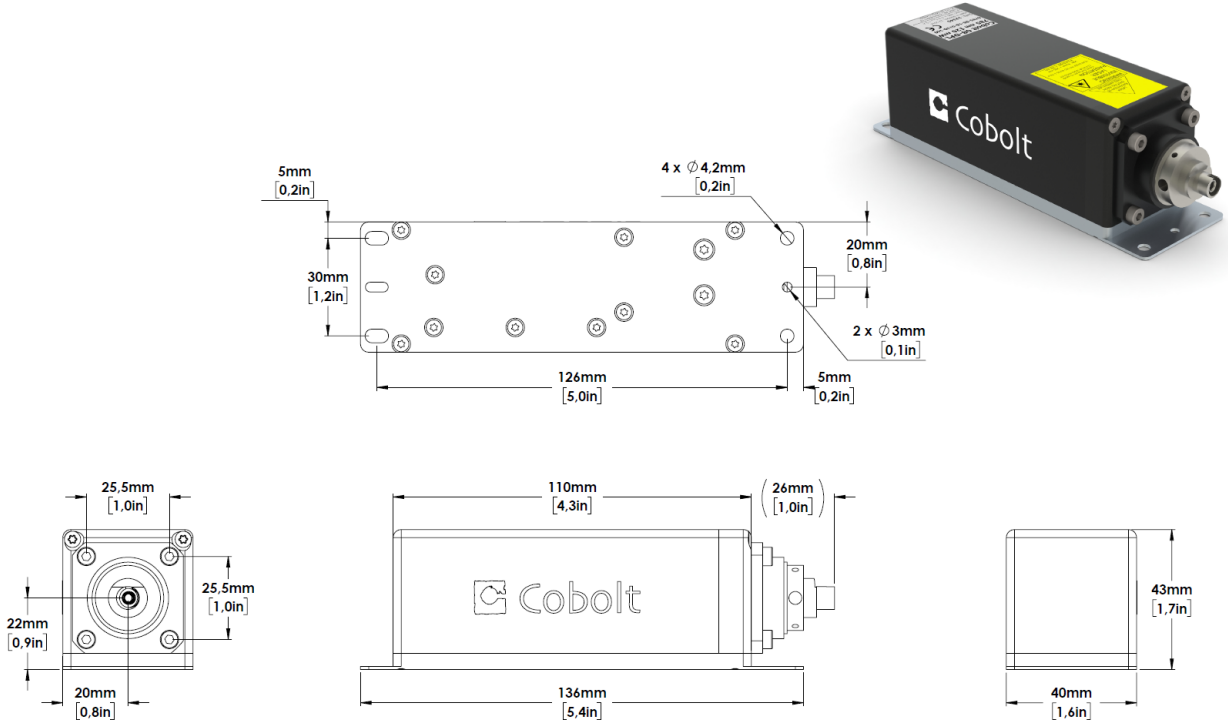

Key Control box

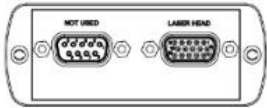
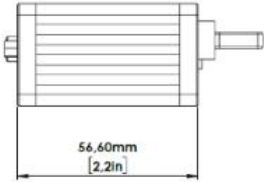
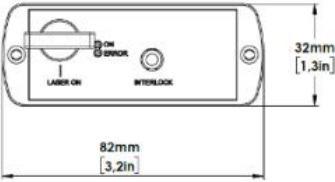
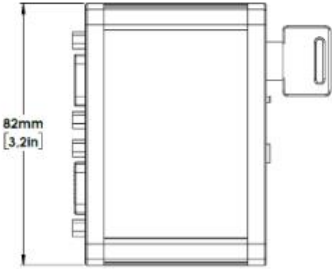

### 5.5. Remote Interlock Connector

The laser is equipped with a remote interlock connector that prevents current flow through the diode when the circuit is open. To close the remote interlock connector with an external switch, connect the two poles of the remote interlock connector (see below).

After the remote interlock connector has been opened the laser will need to be reset before it can be used again. After closing the remote interlock circuit after a remote interlock break, the laser function can be resumed via computer control, by resetting the power supply, or by turning the key switch to ON (CDRH model). The signal level is between 0 V and +5 V with a pull up resistor, and the current required to ground the remote interlock is 5 mA. The time delay in the hardware is < 1 ms, but after filtering by the firmware the reaction time is extended to < 20 ms.

#### o8-DPL and o8-NLD(M) 785nm

In OEM configuration the remote interlock connector is located at pin 1 and 2 of the Molex connector on the back side of the laser head. In CDRH configuration the remote interlock connector is located on the control box and a 3.5 mm mono plug is provided to short the circuit. To use the remote interlock connector with an external switch a 3.5 mm stereo plug is required. The ring and sleeve (see figure) must be connected for the laser to operate.

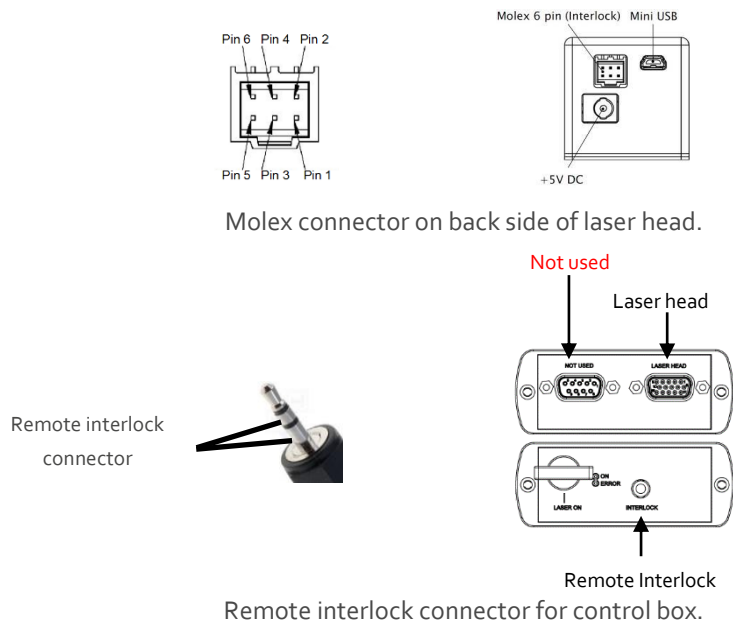

#### o8-NLD

The remote interlock connector is a 2.5 mm female stereo (TRS) audio socket. The ring and sleeve (see figure) must be connected for the laser to operate. To use the remote interlock connector with an external switch, connect a 2.5 mm stereo plug instead.



## 5.6. Direct On/Off control

### o8-DPL and o8-NLD(M) 785nm

Direct On/Off control is only available for OEM configurations and is not CE / CDRH compatible. The Direct On/Off control feature enables turning the laser On/Off using a 5 VDC signal. After having configured the laser for Direct Input operation, the laser can only start-up when 5 VDC (max 12.5 VDC) is applied to pin 3 on the Molex connector, with 0 VDC on pin 2 as reference. Shifting the signal to 0 VDC on pin 3 will turn the laser off and put the laser in stand-by mode. This input only controls the on/off state of the laser and cannot be used to modulate the power output. The remote interlock connection between pin 1 and 2 must also be made as described in section o.



**NOTICE** The Direct on/off feature should never be used as remote interlock connector. A remote interlock socket is provided for this purpose on the laser head.

### o8-NLD

The Direct On/Off on the o8-NLD can be used out of the box with no connection to a computer. It allows the user to completely shut off the diode. The on/off function feature can be accessed via a socket on the key control box (CDRH model) or pin 11 on the laser head's D-SUB (OEM model).

The on/off socket is connected to a floating voltage line. When this line is grounded or forced to zero, the laser automatically enters direct on/off mode in the off state. Only a very small current (< 500  $\mu$ A) must flow in order to ground the circuit. A 5 V signal should be applied to turn the laser on. The laser will remain in direct on/off mode until the laser is restarted. The on/off socket takes a 3.5 mm stereo audio plug. The plug should be connected as shown in the figure below.

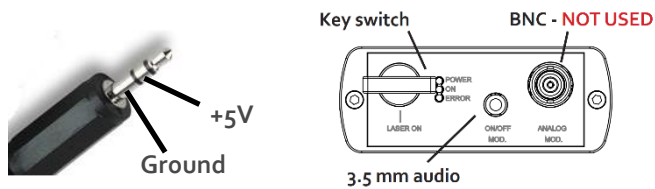

In Cobolt Monitor™ software there is a check box for "On/Off Modulation", which indicates when on/off mode is enabled. The laser automatically detects when an on/off signal is present and enables "On/Off Modulation", so there is no need for the user to check the "On/Off Modulation" box manually. To disable "On/Off Modulation" it is necessary to open the Cobolt Monitor™ and uncheck the box. In the field next to this check box the user can set the output power level that the laser emit in the 'ON' state. This is set in the factory to the laser's nominal maximum power level.

### 5.7. Pin assignment

#### o8-DPL and o8-NLD(M) 785 nm

The pin configuration of the Molex connector on the laser head and control box is described in the table below. Note the pin orientation with respect to the lock position of the socket.

Pin	Signal
1	Remote interlock
2	0 V – Ground
3	Direct On/Off (+5 V Input)
4	Key Switch
5	LED 1 (Laser On)
6	LED 2 (Error)

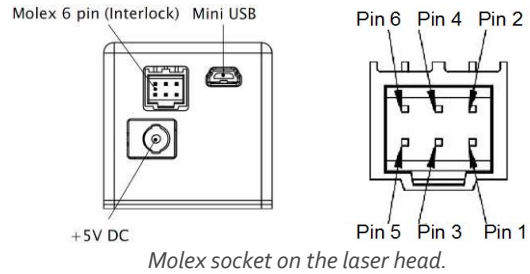

#### o8-NLD

The pin configuration for the 15-pin D-SUB on the o8- NLD laser head and all o8-o1 series key control boxes are described in the table below.

Pin	Function
1	LED1 (Laser on)
2	LED2 (Error)
3	<i>Not used</i>
4	0 V (ref pin 1,2,3,5,6,7,8,11,12)
5	Key Switch
6	Remote interlock connector
7	RS-232 TX
8	RS-232 RX
9	Spare
10	0 V GND (ref pin 15)
11	Direct On/off
12	<i>Not used</i>
13	<i>Not used</i>
14	<i>Not used</i>
15	+5V to keybox

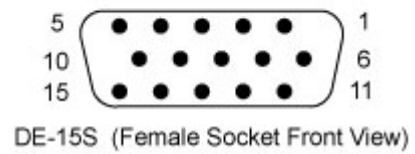
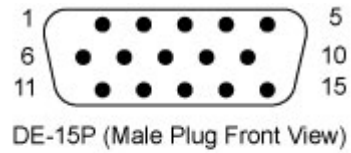

## 6. Operation instructions

### 6.1. Start-up procedure

As soon as power is supplied to the laser head the auto-start procedure will begin. Light will be emitted once the remote interlock is connected, the shutter is open and when the key is turned to the ON position (CDRH model). The specification parameters are not guaranteed over time periods of greater than 8 hrs for constant power mode.

### 6.2. Installation start-up operation

1. Mount the laser head on a suitable heat sink (see Section 4.6).
2. Ensure that the remote interlock jumper is connected.
3. Connect the key control box to the laser head.
4. Connect the 5 VDC power supply to the mains outlet and then to the laser head.
5. The laser now goes through the following auto-start sequence:
  - Temperature stabilization (1-2 min). Status LEDs: POW flashing, then POW goes on.
  - Turn the key switch to start the laser. Status LEDs: ON goes on (CDRH model only)
  - The laser starts (light is emitted) in a constant warm-up current constant for 60 sec. Status LEDs: ON goes on.
  - The laser locks to pre-set output power (< 3 min) and operates according to specifications. Status LEDs: LOCK goes on.



**NOTICE** If the power does not match the power as stated on the test sheet see Section 12: Service for more information.

### 6.3. Shutdown procedure operation

1. Turn the key switch to OFF first (CDRH models only).
2. Disconnect PSU from mains outlet.
3. Disconnect laser from PSU.

## 7. Operating modes

The laser can only operate in continuous-wave mode. There are two operating modes: constant power and constant current. When delivered, Cobolt o8-DPL and o8-NLD(M) 785 nm lasers are by default set in constant power mode. In constant power mode the power is monitored on an internal photodiode, and this is used to regulate the current to maintain a constant power level. Cobolt o8- NLD lasers are set in constant current mode. All laser are delivered with auto-start enabled. In constant current mode the laser runs at a set current level.

## 8. Cobolt Monitor software

The Cobolt Monitor software provides a graphical way to monitor the laser performance and to change power, operation mode, and other settings.

Cobolt Monitor™ has been tested with operating systems Windows XP, Windows Vista, Windows 7, Windows 8 and Windows 10. Microsoft .NET 4.0 is required to run the Cobolt Monitor™ software. Most computers with operating systems Windows XP, Windows Vista, Windows 7 and Windows 8 have this included as standard. When using versions of Windows older than Windows 10, a USB driver may be required. See Section 9 for details on installation. The USB driver can be downloaded from the Hübner Photonics website (<https://hubner-photonics.com/>).

### 8.1. Installation

Download the latest version of the Cobolt Monitor™ software for the o8-01 Series from the Hübner Photonics website (<https://hubner-photonics.com/>). The Cobolt Monitor™ software is a stand-alone executable. The executable file is packaged with other files needed to run the program in a .zip file. Save the .zip file to any storage device, and extract all files. The folder created after extracting the files can be placed on any storage device and Cobolt Monitor™ can be run from there. All files and folders contained in the .zip file must be present for the program to function properly.

### 8.2. Software instructions

The software automatically searches for Cobolt devices every 5 seconds and automatically connects the laser if detected.

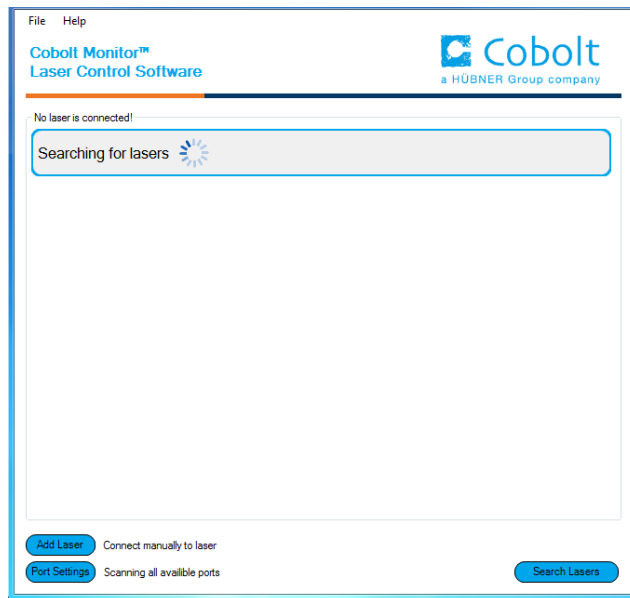

*The first Cobolt Monitor™ window that appears in the Cobolt Monitor software.*

Once the laser is connected it can be controlled from the box dedicated for the laser. The interface, found in the following figure, is intended for typical user cases. Only the relevant information is presented on this level, displaying only the status the laser is in and relevant choices to make. Here follows a short description of how to use the Cobolt Monitor™ software on this level.

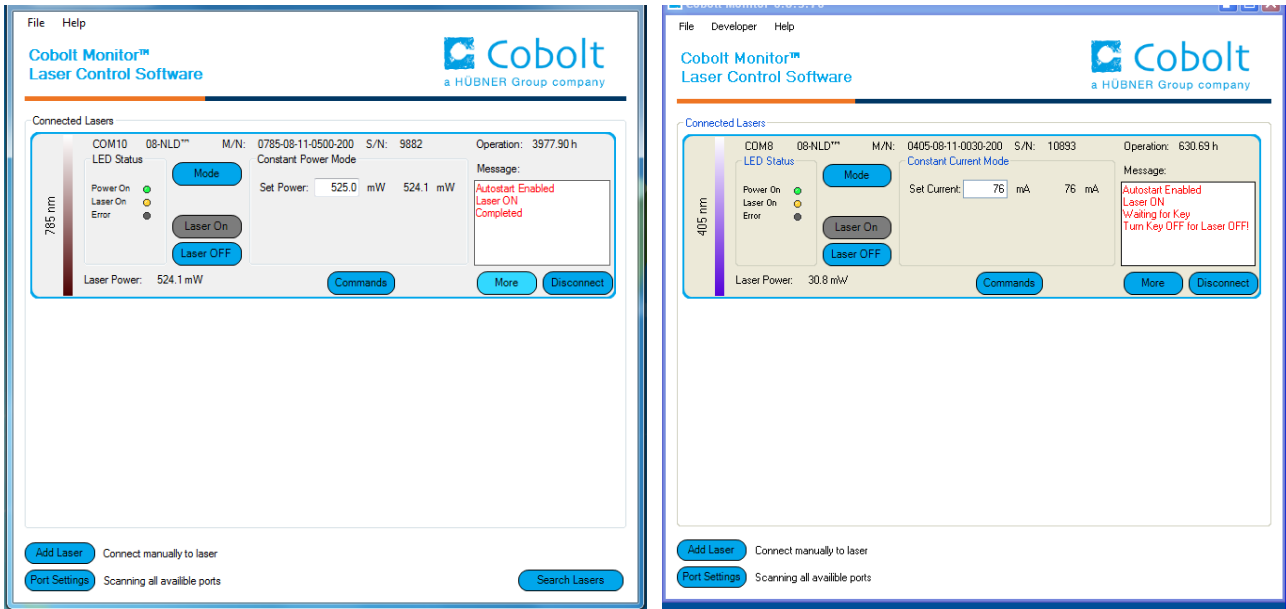

GUI interface successfully connected to a laser

**Laser ON** – Turns the laser ON. If the laser is in autostart mode this is equivalent to “restart”.

**Laser OFF** – Turns the laser OFF.

**Mode** – Gives a choice of operational modes possible to choose for the laser model. For Cobolt o8-01 series laser models Constant Power or Constant Current operation can be chosen. Only relevant choices for the mode of operation are presented.

**Commands** – opens a command communication window to send commands directly to the laser controller.

**Message** – highlights important information of the laser status to the user.

**Disconnect** – allows to disconnect the GUI in a controlled way. To disconnect the laser click “Disconnect” or close the GUI completely. It is also possible to disconnect by powering the laser OFF. In this case the GUI will automatically close the GUI windows of the laser.

**More** – opens an additional GUI window containing more detailed information of the laser status (see below).



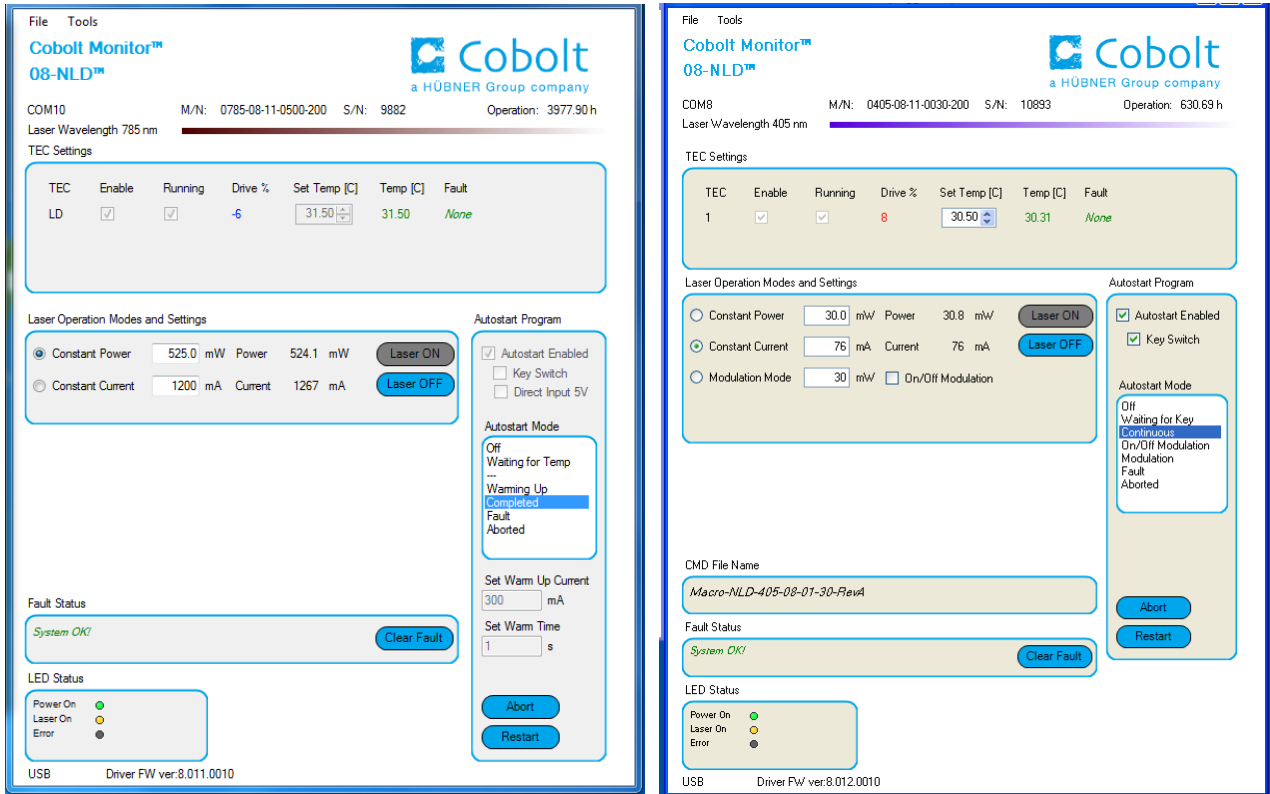

Cobolt Monitor with a second GUI layer expander revealing a more detailed monitoring of the laser.

**TEC Settings** – shows the running status and the fault status for the laser’s internal thermoelectric coolers (TEC). Only activated model specific TEC’s are displayed.

**Laser Operation Mode and Settings** - displays the set laser power. The user can switch between constant power mode and constant current mode. Likewise, there are boxes to set the constant power level and constant current level. The output power (measured on an internal photodiode) and the current through the laser pump diode are both displayed. Changing the laser output power or operating current may negatively impact the performance of the laser.

**Autostart Program** - displays whether the laser is in CDRH or OEM mode and displays the current laser operational status. There are also buttons to “abort” the autostart sequence or to “restart” the laser after a fault.

**Fault Status** – displays ERROR messages. In the event of an ERROR the laser action is stopped. When the cause for the ERROR event is understood and the problem is addressed the fault status can be cleared with “Clear Fault”. If the Autostart Program is enabled click “Restart” to restart the laser.

**LED Status** - The LEDs display the lasers status. The LED section does not correspond to any physical LED’s. LEDs:

<b>POWER</b>	Green	Power is supplied.
<b>ON</b>	Orange	Laser emission is on.
<b>ERROR</b>	Red	An error has occurred.

## 9. Operation via data port

### 9.1. Data port connections

All o8-01 Series lasers can be connected to a data port via mini-USB connection on the laser head for USB or RS-232 communication. Additionally, depending on configuration, the o8-NLD offers data connection via RS-232 from the key control box. A suitable cable is provided.

### 9.2. Handshaking

Under no circumstances does the system initiate communication; it only transmits characters in response to a message. Every message generates a response, either a numerical value or the acknowledgment string "OK". In the event that the system receives a message that it cannot interpret, it responds: "Syntax error: illegal command". Every system response is terminated by a carriage return (ASCII 13) and a full stop is used with floating numbers.

### 9.1. RS232 communication

The main USB port on the laser head is configured for either USB or RS-232 communication. RS-232 configured system is shipped from the factory with a fixed baud rate (115200). Cobolt o8-NLD STM lasers are all delivered with RS-232 communication available via the key control box or Sub-D I/O port on the laser head. The other serial port parameters are: 8 data bits, 1 stop bit and no parity. Hardware flow control is not supported. Each command must be terminated by a carriage return. All commands are case-sensitive. Leading and trailing white space is ignored, but command arguments must be delimited by a single space character (ASCII 32).

### 9.2. USB driver

The appropriate drive for the USB configured devices will be automatically installed on the computer with Windows 10 operating system (or later) when the laser is connected for the first time. When using a computer with another operating system the USB driver must be downloaded from the Hübner Photonics website (<https://hubner-photonics.com/>).



**NOTICE** If using an RS-232 configured device, do not install the USB driver, regardless of operating system.

### 9.3. Communication commands

The laser is delivered with the laser set in Auto-start mode (see section 6.2 for Auto-start sequence description). For system integration the Auto-start sequence can be disabled in order to avoid the laser emitting automatically when power is supplied. As long as power is supplied to the laser the temperature control elements are always operating to reach set-point values. All arguments are in lower case and separated by a space (ASCII 32). For restarting the laser with control commands after having opened the remote interlock switch, execute “cf” for clear fault followed by “@cob1” to restart the laser. On CDRH models the key switch is the only way to restart.

Command	Function	Argument	Returned value
l?	Get laser ON/OFF state		0 = OFF 1 = ON
hrs?	Get laser head operating hours		Operation hours
ilk?	Get remote interlock state		0 = OK 1 = remote interlock open
@cobas	Enable/disable autostart	0 = disable 1 = enable	
@cobas?	Get autostart enable state		0 = disabled 1 = enabled
@cob1	Laser ON Starts the laser including the warm-up phase, without enabling autostart permanently		
lo	Laser OFF		
p?	Get output power set point		Power (W)
p	Set output power	Power (W)	
pa?	Read output power		Power (W)
i?	Get drive current		Current (mA)
slc	Set drive current	Current (mA)	
cp	Enter constant power mode		
ci	Enter constant current mode		
f?	Get operating fault		0 - no errors 1 – temperature error 3 – remote interlock error 4 – constant power time out
cf	Clear fault		
gsn?	Get serial number		Serial number

#### o8-DPL and o8-NLD(M) 785 nm Only

@cobasdr	Enable/disable direct control See section 5.6 for description (OEM models).	0 = disable, 1 = enable	
@cobasdr?	Get direct control enable state		0 = disabled 1 = enabled

## 10. Troubleshooting

Below are some possible problems along with a list of things to check if the problem occurs.

### No laser emission after 3 minutes from start-up

- Verify that the remote interlock is connected and restart the laser.
- Verify that auto-start is enabled. Click the restart button in the Monitor software or send the command "@cob1" to force a restart of the laser.
- Ensure the laser has adequate heat sinking.
- Verify that the supply voltage is within the range stated in section 4.7.
- Send the command "f?"
  - If fault code 1 is returned, check that the heat sink is adequate and that the ambient temperature is below 40 °C.
  - If fault code 3 is returned, see remote interlock fault checklist.
  - If fault code 4 is returned, there may be a problem with the constant power system. Contact Cobolt technical support.

### Remote interlock fault

- If using a custom remote interlock system, connect the Cobolt-supplied remote interlock mono plug to check whether the remote interlock is correctly wired. The remote interlock should be connected as described in section 0.
- In the software, check that "Interlock Fault" is not displayed. Send the command "ilk?" to confirm that the remote interlock is not open (returns "1" if closed).
- If it is verified that the remote interlock system is closed and yet a remote interlock fault is returned, contact Cobolt technical support.

### Laser emission stops

- Ensure that the laser has adequate heat sinking.
- Check that the remote interlock is connected.
- Send the command "f?"
  - If fault code 1 is returned, check that the heat sink is adequate and that the ambient temperature is below 40 °C.
  - If fault code 3 is returned, see remote interlock fault checklist.
  - If fault code 4 is returned, there may be a problem with the constant power system. Contact Cobolt technical support.

### Low power

- Check that the laser is in constant power mode (using the GUI or the "cp" command).
- Check the power reading using the GUI or the "pa?" command.
- Send the command "f?"
- If fault code 4 is returned, there may be a problem with the constant power system. Contact Cobolt technical support.

## 11. Warranty and maintenance

The Cobolt lasers should not be opened for any reason. The warranty will be void if any of the system units are opened. All laser parameters are set at the factory, and there are no adjustments required (other than those described in this manual for operating in different modes and at different power levels).

Cobolt o8-DPL, o8-NLD 405 nm and o8-NLD(M) 785 nm lasers are provided with a system warranty of 24 months after delivery with unlimited hours of operation. Other Cobolt o8-NLD wavelengths are provided with a system warranty of 12 months after delivery with unlimited hours of operation. The warranty on the fiber pigtailed (o8-03) option is 12 months on faulty workmanship, with the existing warranty on laser itself. Warranty is invalid if the laser system is operated outside of the specific limits and conditions as outlined in this document.

## 12. Service

Due to accuracy tolerances, calibration differences, and allowed power drift, there may be discrepancies between the Cobolt measurement of the optical output power and the customer measurement equipment. If the output power deviates from the reported value, please contact your local Cobolt representative for an online re-calibration.

If the laser does not function, do not attempt to open any of the units, or the warranty will be voided. Call or e-mail your local Cobolt representative for consultancy and to request an RMA number (see back cover for contact information). If an RMA number is issued and the laser needs to be shipped back to Cobolt or your local representative, please pack the complete system for shipment using the original package or equivalent. Ensure the unit is free from thermal paste before packing. The warranty covers repair or replacing the unit at the option of Cobolt.

## 13. Disclaimers

Cobolt will assume no responsibility for damage incurred by faulty customer equipment, such as measurement equipment, cables etc, used in conjunction with Cobolt lasers. Cobolt makes no warranty of any kind with regard to the information contained in this guide, included but not limited to, implied warranties of merchantability and suitability for a particular purpose. Cobolt shall not be liable for errors contained herein nor for incidental or consequential damages from the furnishing of this information. No part in this manual may be copied, reproduced, recorded, transmitted, or translated without the express written permission by Cobolt.

## 14. Compliance (CDRH models only)

The CDRH model lasers (-1/300) are designed and manufactured to comply with the EC Low Voltage Directive and the EC EMC Directive in the CDRH-compliant configuration of laser head, key control box, key and Cobolt-supplied power supply. All equipment must be mounted on a common ground plane, such as an optical table. If any part of the delivered equipment is replaced with a part not supplied by Cobolt or if the equipment is not properly grounded, the system may not conform to CE / CDRH compliance standards listed in this section. Disabling any of the safety features nullifies the CE marking and violates the laser safety standard.



The following harmonized and limits standards have been applied:

<b>Electrical Safety</b>	EN 61010-1, IEC-61010-1, UL 61010-1 (Limited Energy System) UK S.I. 2016 No. 1101 : The Electrical Equipment (Safety) Regulations 2016
<b>Laser Safety/Class</b>	IEC-60825-1 FDA / CDRH : Complies with 21 CFR 1040.10 and 1040.11 except for conformance with IEC 60825-1 Ed. 3., as described in Laser Notice No. 56, dated May 8, 2019.
<b>EMC</b>	IEC 61326-1 EN 55011                      Electromagnetic Emission , Class A Electromagnetic Immunity – Table 2 Requirements EN 61000-4-2                Electrostatic Discharge ±4 kV contact discharge and ±2 kV, ±4 kV, ±8 kV air discharge EN 61000-4-3                Radiated electromagnetic fields 80 – 1000 MHz, 10 V/m with 80 % AM @ 1 kHz 1.4 – 2.7 GHz, 3 V/m with 80 % AM @ 1 kHz EN 61000-4-4                Fast transient / Burst AC Power input port ±2,0 kV EN 61000-4-5                Surge AC Power input port ±0,5 kV, ±1,0 kV, ±2,0 kV Com. Mode AC Power input port, ±0,5 kV, ±1,0 kV Diff. Mode EN 61000-4-6                Conducted Immunity 3 V with 80 % AM @ 1 kHz EN 61000-4-11               Dips and Interruptions 50 Hz and 60 Hz. Test voltages: 100 V and 230 V  UK S.I. 2016 No. 1091 : Electromagnetic Compatibility Regulations 2016 FCC 47 CFR - Part 15 (2009): Subpart B, Class A
<b>RoHS</b>	EU Directive 2011/65/EU, EU 2015/863 and amendment EU 2017/2102 UK S.I. 2012 No. 3032

Contact your sales representative for a copy of the full Declaration of Conformity.





## Our Locations

### Cobolt AB

(Sales in Norway, Sweden, Finland and Denmark)

Solna, Sweden

Phone: +46 8 545 912 30

Fax: +46 8 545 912 31

E-mail: [info@coboltlasers.com](mailto:info@coboltlasers.com)

### HÜBNER Photonics GmbH

(Sales in Germany, Switzerland and Austria)

Kassel, Germany

Phone: +49 561 994 060-0

Fax: +49 561 994 060-13

E-mail: [info.de@hubner-photonics.com](mailto:info.de@hubner-photonics.com)

### HÜBNER Photonics Inc.

(Sales in USA, Canada and Mexico)

San Jose, California, USA

Phone: +1 (408) 708 4351

Fax: +1 (408) 490 2774

E-mail: [info.usa@hubner-photonics.com](mailto:info.usa@hubner-photonics.com)

### HÜBNER Photonics UK

(Sales in UK and Ireland)

Great Britain

Phone: +44 735 944

E-mail: [info.uk@hubner-photonics.com](mailto:info.uk@hubner-photonics.com)

[www.hubner-photonics.com](http://www.hubner-photonics.com)

**HÜBNER Photonics**

