

Cobolt Skyra™

Compact | Plug and play | Multi-line Laser

405 nm	515 nm	633 nm
445 nm	532 nm	638 nm
457 nm	553 nm	647 nm
473 nm	561 nm	660 nm
488 nm		



CONTENTS

1.	Introduction	5
2.	Safety	6
2.1.	General	6
2.2.	Fiber Coupled Option	7
2.3.	Accessible emission information for Cobolt Skyra™ laser lines	7
2.4.	Safety features	8
2.5.	Warning and Identification Labels	9
2.6.	Equipment Safety	10
3.	Constant Power Quick Start – CDRH Models	11
4.	Cobolt Monitor™ Software	12
4.1.	Installation	12
4.2.	Software instructions	12
5.	Modulation Quick start	16
5.1.	Settings	16
5.2.	DPL Modulation Inputs (Laser 1)	17
5.3.	MLD Modulation inputs (Laser 2, 3 and 4)	18
6.	Closedown operation	18
7.	System Overview	19
7.1.	Model number	19
7.2.	Configuration	20
7.3.	Laser head	21
7.4.	Key control box	21
7.5.	Thermal management	22
7.6.	Power supply requirements	22
8.	System Description	23
8.1.	Specification	23
8.2.	Mechanical Drawings	26
8.3.	Remote Interlock Connector	28
8.4.	Direct On/Off control	29
8.5.	Pin assignment	30
9.	Continuous wave operation	32
9.1.	Emission control in CW operation	32
10.	Modulation mode operation	36
10.1.	Digital modulation	37
10.2.	Analog modulation	38
10.3.	Internal modulation	39
10.4.	Modulation mode combinations	39
10.5.	Settings Optimization in modulation mode (Laser 1 : DPL Only)	40
11.	Operation via data port	41
11.1.	Handshaking	41
11.1.	RS232 configured controllers	41
11.2.	USB driver	41
11.3.	Communication commands	44
12.	Troubleshooting	47
13.	Warranty and Maintenance	49
14.	Service	49
15.	Disclaimer	49
16.	Compliance (CDRH models only)	50

1. Introduction

Cobolt Skyra™ is an extremely compact, permanently aligned, plug & play, multi-line laser with up to 4 laser lines and control electronics integrated into one single, temperature-controlled package, small enough to fit in the palm of your hand!

The laser is built using Cobolt's proprietary HTCure™ manufacturing technology for robustness in a compact, hermetically sealed package. HTCure™ results in an ultra-stable, permanent alignment of optical elements, with very precise and stable overlap of the combined output beams.

The Cobolt Skyra™ is available in a free beam or fiber coupled configuration. It is intended for stand-alone use in laboratory environments or for integration as OEM components in instruments for applications including biomedical research, fluorescence microscopy, flow cytometry, as an Argon ion replacement in microscopy instrumentation and optogenetics.

2. Safety

2.1. General

The laser classification of Cobolt Skyra™ is dependent on the specific laser lines present a multi-line laser. The wavelengths and maximum accessible emission can be found on the warning label on the laser head. See section 2.5 for detailed information on warning and identification labels.

The sum of the maximum emitted power of all laser lines in the multi-line laser determines the laser classification. The residual emission at wavelengths outside the specified range do not exceed Laser Class 1. A multi-line laser capable of emitting less than 500 mW of laser radiation within the visible spectrum (405 nm – 660 nm) is Class IIIB (CDRH), Class 3B (IEC).



A multi-line laser capable of emitting more than 500 mW of laser radiation within the visible spectrum (405 nm – 660 nm) is Class IV (CDRH), Class 4 (IEC).



Eye and skin exposure to direct or reflected laser light is hazardous and may be extremely harmful. Always wear eye protection appropriate to the beam wavelength(s) and intensity and never look directly into a laser beam. Laser radiation may ignite flammable materials and combustible gasses in the beam path, and, in event of ignition, fumes may be generated. All equipment used in close proximity to the laser beam should be suitably fire resistant and the facility should be properly ventilated. It is advised to perform a risk assessment for the facility and equipment prior to using the laser. In the case of integration into a larger system, laser safety compliance must be evaluated in the end product. The device must be handled by skilled personnel experienced with lasers, in a laboratory environment and with access to adequate laser safety equipment. The laser head clearly displays a yellow warning label that shows the location of the laser beam aperture. This label must be visible unless the laser beam is totally enclosed. If the laser does not function, do not attempt to open any of the units, or the warranty will be voided. Call or e-mail your local Cobolt representative for consultancy and to request an RMA number (see back cover for contact information).



CAUTION Use of controls or adjustments or performance of any procedures other than those specified herein may result in exposure to hazardous radiation.

2.2. Fiber Coupled Option

All safety recommendations in section 2 are also valid for the Cobolt Skyra™ fiber coupled laser heads. Additionally, heat generated from absorption of laser radiation by particles on the fiber end may increase the probability of ignition hazards in certain environments. Always clean the fiber end before turning on the laser. In systems where the beam is exposed, fiber end must be mounted < 2 m from the emission warning LED. It is advised to perform a risk assessment for the facility and equipment prior to using the laser. In the case of integration into a larger system, laser safety compliance must be evaluated in the end product.

2.3. Accessible emission information for Cobolt Skyra™ laser lines

The table below describes the irradiance in W/cm² and appropriate level of eye protection in terms of optical density (OD) for each product line. Using a multi-line laser requires a combination of eye protection that is specifically tailored to the device configuration. Be sure to consider all available wavelengths and power levels when selecting eye protection.

Laser line	Nominal Output Power (mW)	Max Power (mW)	Max Irradiance (W/cm ²)*	Eye protection Requirement (OD)**
Cobolt MLD 405 nm	50	120	50	4
	100	120	50	4
Cobolt MLD 445 nm	50	120	42	4
Cobolt MLD 457 nm	50	120	42	4
Cobolt MLD 473 nm	50	120	42	4
	100	350	124	4
Cobolt MLD 488 nm	50	80	28	3
	100	250	78	4
Cobolt MLD 515 nm	50	100	35	3
Cobolt DPL 532 nm	50	150	53	3
	100	300	106	3
Cobolt DPL 553 nm	50	100	32	3
Cobolt DPL 561 nm	50	150	48	3
Cobolt MLD 633 nm	50	100	35	3
Cobolt MLD 638 nm	50	120	71	3
Cobolt MLD 647 nm	50	150	53	3
Cobolt MLD 660 nm	50	130	46	3

* Irradiance (W/cm²) = Max Power (W) ÷ Beam Area at bottom tolerance (cm²)

** Eye protection (OD) = Log₁₀(Max Power (W) ÷ 60825⁻¹ Emission Limit : Class 1 (W)), rounded up to the next integer.



CAUTION Always wear the appropriate eye protection for all of the specified emitted wavelengths. Verify the accessible emission wavelengths and power levels on the warning label before operating.

2.4. Safety features

The laser is equipped with all required safety features as described in the laser safety standard IEC 60825-1. If any part of the delivered equipment is replaced with a part not supplied by Cobolt or if the equipment is not properly grounded the device may not conform to CE / CDRH compliance standards listed in section 16. Disabling any of the safety features nullifies the CE marking and violates the laser safety standard.

Remote Interlock Connector

The remote interlock connector is a connector which permits the connection of external controls placed apart from other components of the laser product. When the terminals of the connector are open-circuited, emission is interrupted and no radiation will be accessible. The remote interlock connector permits easy addition of an external interlock in laser installation. See section 8.3 for a detailed description of the remote interlock circuit and operation.

Manual Shutter (Beam Stop)

The laser head is equipped with a manual shutter, which functions as the beam stop, capable of preventing human access to laser radiation. In the case of the fiber coupled, front the screw-on cap functions as the shutter. The aperture location and the open and close positions of the shutter are indicated on the top surface of the laser head.

Key Control

The CDRH compliant model comes with a key control box which must be connected for the laser to operate. When the key is in the OFF position, the diodes are prevented from emitting. The key must be actively turned to the ON position each time the laser is powered on. When the key is removed from the key control box, laser radiation is not accessible.

Laser Radiation Emission Warning

The key control box, which is part of the CDRH compliant models, incorporates LEDs which indicate the status of the Laser. The "ON" LED is illuminated whenever the device is emitting or could emit light. See section 7.4 for details on the key control box. The emission warning indicators are also visible in the Cobolt Monitor™ software, see section 4 : Cobolt Monitor™ Software for details on the control software.

2.5. Warning and Identification Labels

The upper face of the laser head contains a yellow label with laser safety warning and classification information, the wavelength and maximum power of the unit. It also shows the location of the laser beam aperture and indicates the open and closed positions of the manual shutter. This label must be visible unless the laser beam is totally enclosed. A silver label showing information about the laser model, manufacture date and location, and the power supply voltage and current, is located on the laser head. Lasers shipped to customers in the USA also contain a label of CDRH compliance.

Manufacturer Identification Labels

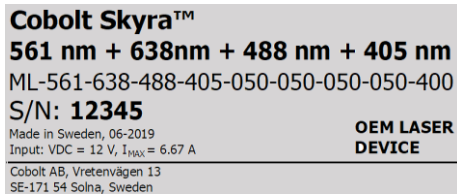

OEM label

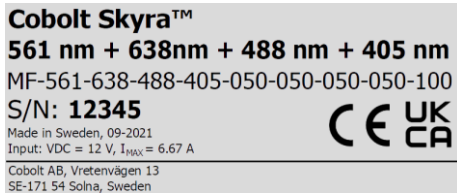

CE /CDRH compliant label

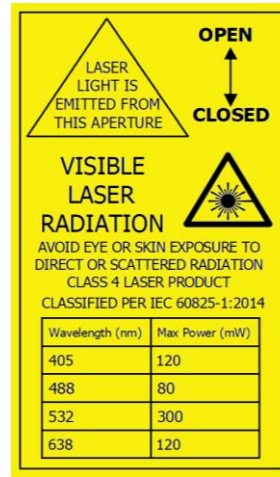

Aperture Warning Labels



Complies with 21 CFR 1040.10 and 1040.11
 except for conformance with IEC 60825-1 Ed. 3,
 as described in Laser Notice No. 56, dated May 8, 2019.

Laser Notice No. 56 Label

CDRH models shipped to USA

2.6. Equipment Safety

2.6.1. Back Reflection Sensitivity

Laser light reflected directly back into the laser head causes damage to the laser diode and results in a dramatic decrease in product lifetime. The MLD lasers with a wavelength greater than 600 nm are particularly sensitive to back reflections; exercise extreme caution.

2.6.2. Electrostatic discharge

Always install the laser power supply to a properly grounded power outlet. Cobolt lasers contain a laser diode which is sensitive to electrostatic discharge (ESD).

2.6.3. Fiber care

It is important to always make sure the fiber end-face is clean before turning the laser on and before connecting the fiber connector in physical contact with another connector. Failure to do so may lead to irreparable damage of the fiber end-face. Do not clean the fiber when the laser is on. We recommend using appropriate equipment for fiber cleaning and inspection.

3. Constant Power Quick Start – CDRH Models

1. Mount the laser on a heat sink or suitable flat surface that provides adequate heat dissipation and connection to ground. Use the four holes on the laser's base plate to secure it.
(HS-05 : <https://www.coboltlasers.com/lasers/options-accessories/>)



2. Attach the 15-pin D-SUB cable to the Control Box.



3. Attach the 10 pin Molex connector to the laser head.



4. Insert the interlock plug into the connector on the key control box.



5. Connect the supplied 12V power supply unit to the socket on the laser head, and plug it in to the mains.



The laser will go through the auto start sequence:

Waiting for Temp	Laser emission is not enabled until all temperatures have reached their set point and the TECs are stabilized.
Waiting for Key	Toggle the key to proceed, if the key is already in the ON position, turn of OFF and ON again.
Warm up	A low current is provided to warm the laser before setting full power
Completed	The device is emitting or armed for emission.

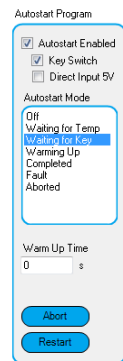

6. To start the laser, turn the key on the key control Box clockwise to the ON position. If it is already in the ON position, turn it to OFF and then ON again. At delivery all laser lines are 'ACTIVE' and 'ON', laser light will be emitted as soon as the key is turned.



7. All laser lines will now start up in continuous-wave, constant power mode at the nominal power level. The power and wavelength may continue to drift slightly for up to 3 minutes while the thermoelectric cooler (TEC) stabilizes.

4. Cobolt Monitor™ Software

The Cobolt Monitor™ software provides a graphical way to monitor the laser performance and to change the output power, operation mode and other settings. Cobolt Skyra™ is compatible with Cobolt Monitor™ 6.0.7.0 and later.

Cobolt Monitor™ has been tested with operating systems Windows XP, Windows Vista, Windows 7, Windows 8 and Windows 10. Microsoft .NET 4.0 is required to run the Cobolt Monitor™ software. Most computers with operating systems Windows XP, Windows Vista, Windows 7 and Windows 8 have this included as standard. When using versions of Windows older than Windows 10, a USB driver may be required. See section 11.2 : USB driver for details on installation.

4.1. Installation

Download the latest version of the Cobolt Monitor™ software from www.coboltlasers.com. The Cobolt Monitor™ software is a stand-alone executable. The executable file is packaged with other files needed to run the program in a .zip file. Save the .zip file to any storage device, and extract all files. The folder created after extracting the files can be placed on any storage device and Cobolt Monitor™ can be run from there. All files and folders contained in the .zip file must be present for the program to function properly.

4.2. Software instructions

The software automatically searches for Cobolt devices and automatically connects the laser if detected. The software can identify USB connected lasers as well as RS232 connected lasers.

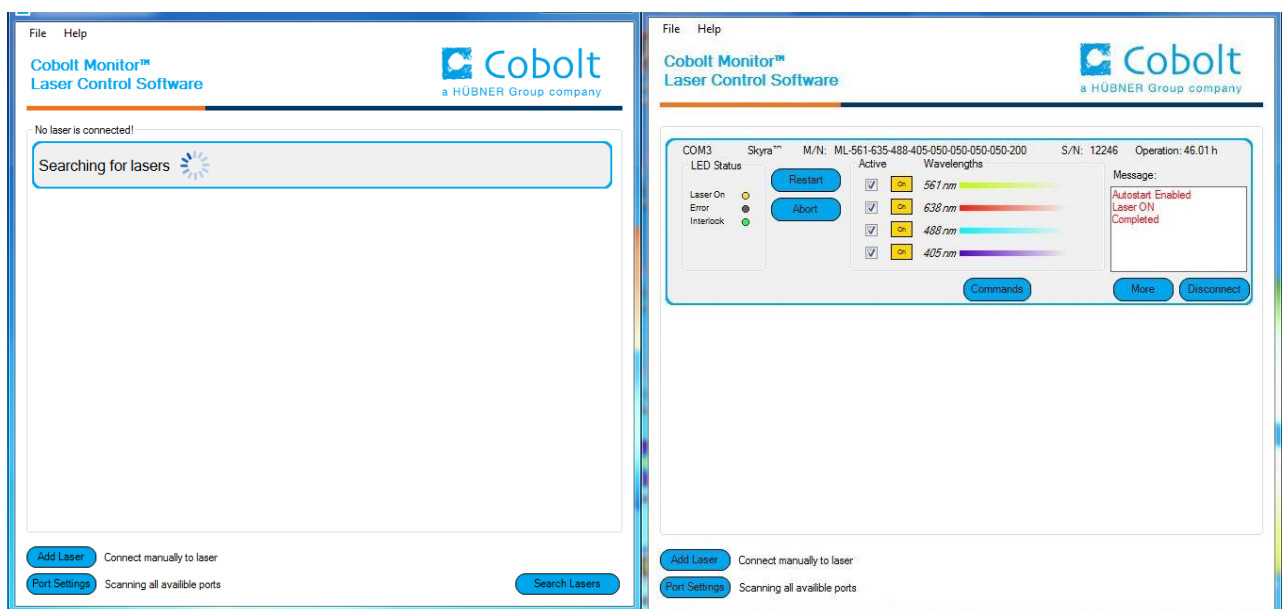

The first Cobolt Monitor™ window that appears in the software.

Once the laser is connected it can be controlled from Cobolt Monitor™ software. Only the most critical information is displayed on this level, including the status the laser is in and the possibility to switch each line ON or OFF (not for modulation). Here follows a short description of how to use the Cobolt Monitor™ software on this level.

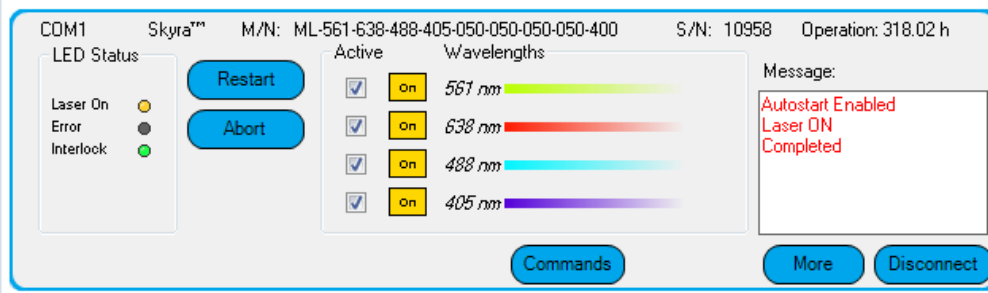

Restart Turns all active lasers ON by re-starting the autostart sequence. If the key switch is enabled, it will need to be toggled OFF and ON again before emission.

Abort Turns all lasers OFF, the autostart sequence must be restarted to resume operation.

Active Check the box to choose the lasers that are active in the autostart sequence.

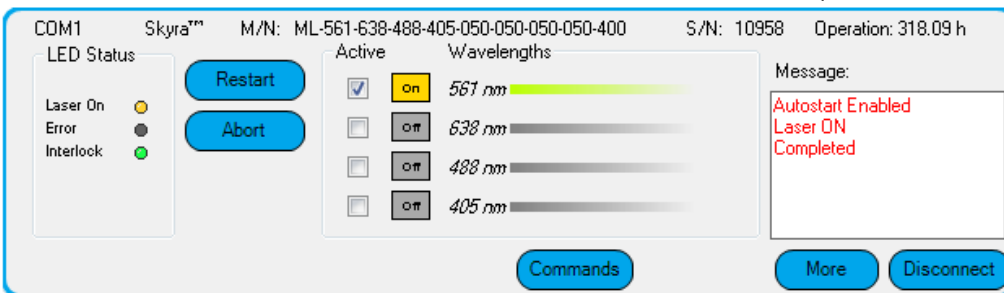

ON/OFF Use these buttons to toggle the individual laser lines ON and OFF after the autostart sequence has been completed. **The ON and OFF buttons are not intended to be used for modulation.**

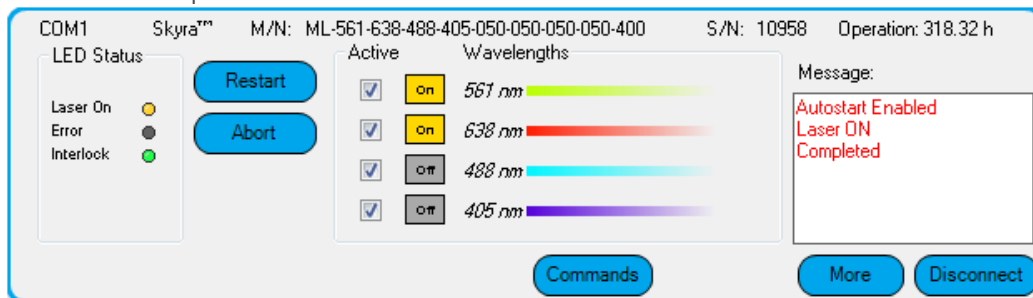

Commands Opens a command communications window to send commands directly to the laser. See section 11.3 : Communication commands for more details on available commands.

Message Highlights important information about the laser status to the user.

Disconnect Allows the user to disconnect from the Cobolt Monitor™ software in a controlled way.

! **NOTE** The communication cable should not be removed when the software is in connected state. To disconnect the laser click "Disconnect" or close Cobolt Monitor™ completely. It is also possible to disconnect by powering the laser OFF. In this case Cobolt Monitor™ will automatically close the window for that laser.

More An additional Cobolt Monitor™ window will open containing more detailed information of that laser's status.

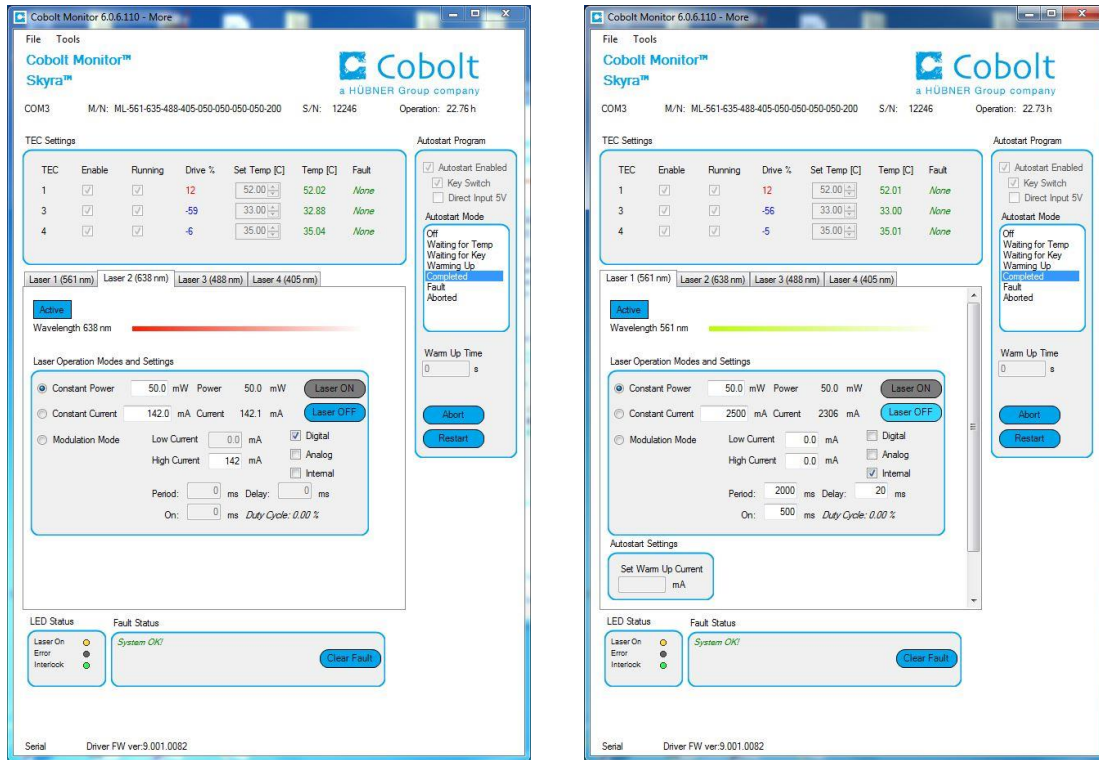

Cobolt Monitor™ software expanded for more detailed monitoring.

TEC Settings Shows the running status and the fault status for the laser’s internal thermoelectric coolers (TEC).

Laser Operation Mode and Settings

Displays the set laser power. The user can switch between **constant power** mode, **constant current** mode and **modulation mode**. Likewise, there are boxes to set the constant power level and constant current level. In constant power mode the current will be set by Cobolt Monitor to reach the power level set in this field. When in modulation mode it is recommended to use an external power meter, the internal measurement will not be reliable. See section 9 and 9.1 for more details on continuous wave and modulation modes. Use the tabs to go from laser to laser.

Autostart Program

Displays whether the laser is in CDRH or OEM mode and displays the current laser operational status. There are also buttons to “abort” the autostart sequence or to “restart” the laser after a fault.

- Waiting for Temp** Laser emission is not enabled until all temperatures have reached their set point and the TECs are stabilized.
- Waiting for Key** Toggle the key to proceed, if the key is in the ON position, turn OFF and ON again.
- Warm up** A current is provided to warm the laser before setting full power.
- Completed** The device is emitting or armed for emission.
- Fault** The device has a fault, the fault status must be cleared before the laser can be restarted.
- Aborted** The autostart sequence has been aborted, but the TECs are still running.

Fault Status Displays ERROR messages. In the event of an ERROR, the laser action is stopped. When the reason for the ERROR event is understood and the problem is addressed the fault status can be cleared with 'Clear Fault'. If the Autostart Program is enabled, click 'Restart' to restart the laser.

LED Status Displays the LEDs that are currently illuminated on the key control box, see section 7.4. These are displayed even if the laser is in OEM mode.

Laser ON	Green	The laser is emitting or armed for emission.
ERROR	Red	An error has occurred.
INTERLOCK	Green	The interlock is in place.
	Red	The interlock is open.

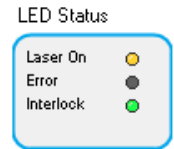

5. Modulation Quick start

The Cobolt Skyra™ is delivered with modulation capabilities on all integrated laser lines. The modulation signal input connectors can be found on the back side of the laser head, there are 8 SMB connectors. The modulation of the Cobolt Skyra™ requires an external signal source, such as a function generator, to drive the modulation. Each of the four laser lines can be modulated individually using both analog and/or digital modulation. Laser 1 is always a Diode pumped laser (DPL). Laser 2, Laser 3 and Laser 4 are Modulated laser diode (MLD) type lasers. There are some critical differences in the control electronics. These impact the modulation parameters and inputs specified in section 8.1.1 : Modulation. To control the laser emission in an irregular way with > 1 second ON time, or on a higher system level see section 9.1 : Emission control in CW operation.



Modulation input SMB Connectors on the back of the laser head.

5.1. Settings

The modulation settings are optimized at the factory with a default modulation frequency of 1 kHz. The settings can be adjusted to optimize performance for the modulation scenario being used. Especially with Laser 1, the DPL, the temperature and modulation current settings can influence the pulse shape. For more detailed instructions on how to adjust the above parameters see Section 10.5 : Settings Optimization in modulation mode (Laser 1 : DPL Only).

Low Current The low current defines the drive current the laser diode is set to in the **OFF** state while in modulation mode. This level can be adjusted to be more suitable for a particular application, but in the case of Laser 1: DPL there can be consequences to the pulse shape.

<u>Laser Line</u>	<u>Low Current Setting</u>
Laser 1 : DPL	Just below the lasing threshold, set at the factory
Laser 2,3 and 4 : MLD	0 mA, factory set

High Current The high current defines the drive current the laser diode will modulate up to while in modulation mode. The default factory setting is the current needed to reach nominal output power in the **ON** state.

TEC3 The TEC3 temperature can be adjusted during modulation of Laser 1. This value is factory set to optimize performance at 1 kHz digital modulation with a 50% duty cycle.

5.2. DPL Modulation Inputs (Laser 1)

Digital Modulation Input signal

- Input signal : 0 – 5 V TTL signal, square wave
 - 0.0 – 1.5 V : OFF
 - 3.5 – 5.0 V : ON
- Modulation Frequency : DC – 5 kHz
- Impedance : 10 kΩ

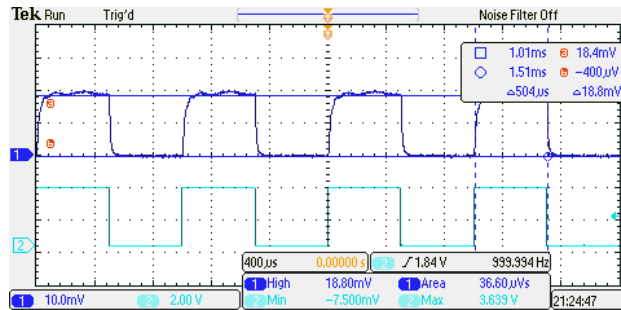

Analog modulation input signal

- Input signal : 0 – 1.0 ± 0.3 V, arbitrary waveform
- Modulation Frequency : DC – 5 kHz
- Impedance : 1 kΩ

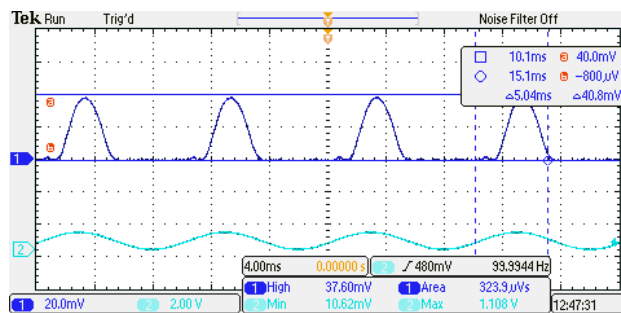

Internal modulation

- Input signal: None. Parameters can be set with Cobolt Monitor™ software or using commands
- Modulation Frequency : up to 500 Hz

5.3. MLD Modulation inputs (Laser 2, 3 and 4)

Digital Modulation Input signal

- Input signal : 0 – 5 V TTL signal, square wave
 - 0.0 – 1.5 V : OFF
 - 3.5 – 5.0 V : ON
- Modulation Frequency : DC – 5 MHz
- Impedance : 1 MΩ

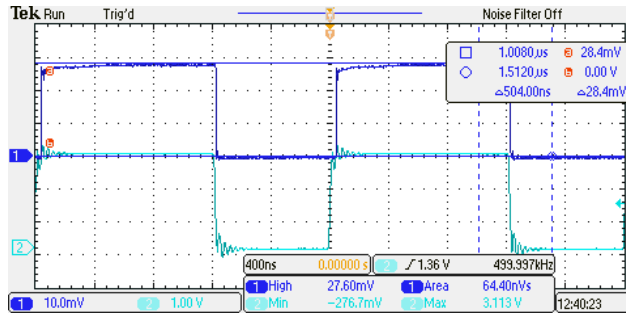

Analog modulation input signal

- Input signal : 0 – 1.0 ± 0.3 V , arbitrary waveform
- Modulation Frequency : DC – 500 kHz
- Impedance : 1 kΩ

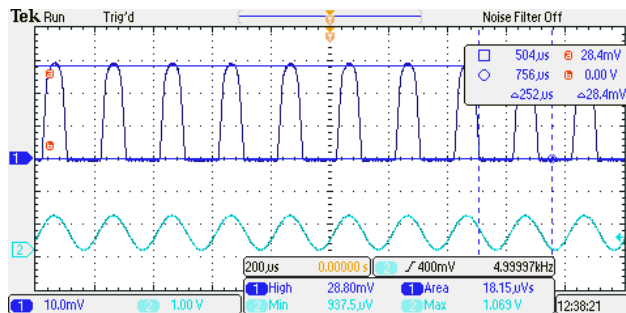

Internal modulation

- Input signal: None. Parameters can be set with Cobolt Monitor™ software or using commands
- Modulation Frequency : up to 500 Hz

6. Closedown operation

1. Turn the key switch to OFF first (CDRH models only).
2. Disconnect PSU from mains outlet.
3. Disconnect laser from PSU.
4. Disconnect laser head from Key control box (only required for shipping).

7. System Overview

Cobolt Skyra™ lasers consist of four main parts: the laser head, key control box, cable between laser head and key control box, and the power Supply (not shown). Always install the laser’s power supply to a properly grounded power outlet. If any part of the supplied equipment is replaced with a part not supplied by Cobolt, or if the equipment is not properly grounded, the system may not conform to CE / CDRH compliance standards listed in section 16. Disabling any of the safety features nullifies the CE marking and violates the laser safety standard.



Cobolt Skyra with CDRH compliant key control box

7.1. Model number

Cobolt Skyra™ lasers are sold in two configurations; CE/CDRH compliant and OEM, described in section 7.2.

The model numbers are composed as described below:

Free beam laser head

ML-AAA-BBB-CCC-DDD-XXX-YYY-ZZZ-QQQ-WWW

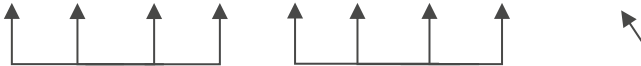

Wavelength :

AAA = Laser 1
 BBB = Laser 2
 CCC = Laser 3
 DDD = Laser 4

Power :

XXX = Laser 1
 YYY = Laser 2
 ZZZ = Laser 3
 QQQ = Laser 4

Configuration :

100 = USB, CE / CDRH Compliant
 200 = USB, OEM
 300 = RS-232, CE / CDRH Compliant
 400 = RS-232, OEM
 xxx = OEM customization

Fiber coupled option

MF-AAA-BBB-CCC-DDD-XXX-YYY-ZZZ-QQQ-WWW



MF : Indicates integrated fiber coupler

7.2. Configuration

7.2.1. CE/CDRH Compliant

The CE/CDRH compliant system is supplied with a key control box, which must be connected, along with a remote interlock connector. Once power is supplied, laser emission starts when the key is turned from the OFF position to the ON position. The status of operation can be monitored via LEDs on the key control box. Setting the key to its OFF position puts the laser in stand-by mode.

The standard CDRH model consists of:

- Laser head
- 12 V / 6.67 A DC power supply unit (Art. Nr. 12522)
- Remote interlock plug (for short circuiting the remote interlock connector on key control box)
- Communication cable
- 10 pin Molex to 15-pin D-SUB cable between laser head and key control box
- Key control box
- Keys

7.2.2. OEM

The laser head is supplied **without** the key control box. Connecting a 12 VDC power supply to the laser head initiates an automatic start-up sequence. If the remote interlock is connected, laser emission will start automatically as soon as power is supplied and internal temperatures are stabilized.

The OEM model consists of:

- Laser head
- 12 V/6.67 A DC power supply unit (Art. Nr. 12522)
- Remote interlock plug (for short circuiting the remote interlock connector on laser head)
- Communication cable

7.3. Laser head

The laser head contains up to four laser cavities, beam shaping optics, thermoelectric coolers (TEC) for temperature control and, for the DPL line, an optical feed-back loop which ensures long-term power stability of the emitted laser beam. The laser head also features a manual mechanical shutter, a laser hazard label and a laser classification label. When power is supplied to the laser head, regardless of direct on/off or key-switch state, the temperature control element will be active to reach its set point values.

7.4. Key control box

The key control box allows the user to operate the laser with a CE/CDRH compliant key-switch. The key control Box has LEDs to indicate the laser status. When power is supplied to the laser head, regardless of key-switch state, the temperature control elements will be active to reach set point values.

The status of the laser operation is given via LED indicators:

- ON** Orange The system is emitting or armed for emission.
- ERROR** Red An error has occurred.



7.5. Thermal management

To ensure operation within given specifications and for the warranty to be valid, the laser head must be mounted on a suitable heat sink. The requirement on thermal resistance of the heat sink can be calculated by taking the difference between the maximum allowed laser head base plate temperature (50 °C) and the ambient temperature at the air-heat sink interface (e.g. 40 °C), divided by the maximum power dissipated from the laser (60 W). The laser head must be attached to a heat sink providing a thermal resistance of < 0.17 K/W at 40°C. The mounting surface should be flat within 0.05 mm over mounting surface. Under normal circumstances thermal heat compound is not required, however if the laser is operated in an area with a high ambient temperature it is recommended to use a thermally conductive compound between the laser head and the heat sink to provide good thermal contact. Cobolt offers a suitable heatsink with fans, Hs-05, For assistance in thermal management and system integration, please contact Cobolt’s technical support.

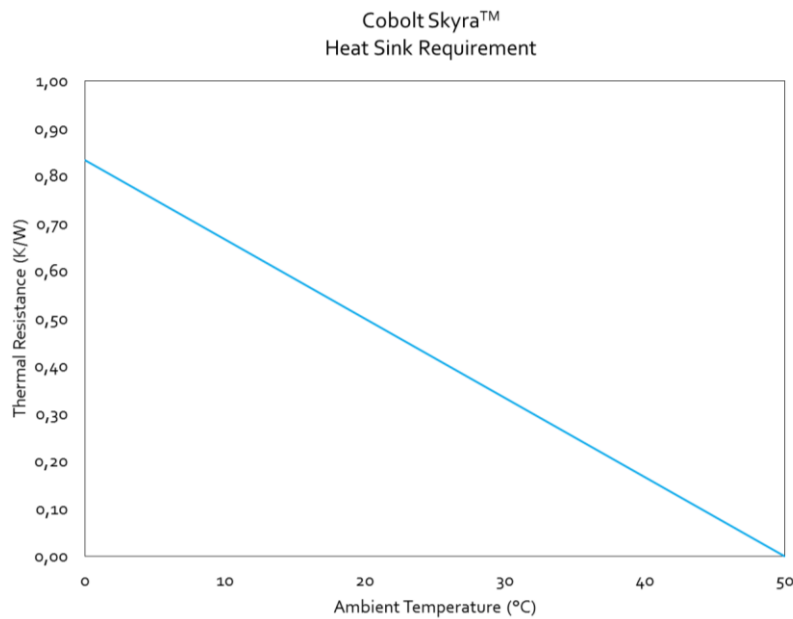

Heat Sink Requirements for Cobolt Skyra™.

7.6. Power supply requirements

An appropriate Power Supply Unit (PSU) is supplied by Cobolt with the laser and can be plugged into a standard power outlet. The power supply accepts 90-264 VAC and 47-63 Hz. Ripple and noise 1% peak-peak max, 20 MHz bandwidth. Accepted voltage range for the laser head is (12.0 ± 0.4) VDC. Specification values are given at 12 VDC. The power supply provided with Cobolt Skyra™ is certified to perform in an ambient temperature of 40°, when integrating this power supply into a larger system care must be taken to ensure that the power supply is not exposed to temperatures above 40°C.

8. System Description

The information presented here is believed to be accurate and is subject to change without notice. The specifications contained herein cannot be guaranteed outside of normal operational conditions. One **DPL** laser line at 532nm, 553nm or 561nm can be combined with any 3 of the **MLD** wavelengths. The wavelength difference between each line must be at least 15 nm.

8.1. Specification

8.1.1. Available wavelengths and power levels

	DPL		
Center Wavelength (nm)	532.1	552.8	561.2
Wavelength precision ¹ (nm)	± 0.3		
Spectral bandwidth (FWHM)	< 1 MHz		
Output power ² (mW)	50 100	50	50

	MLD									
Center Wavelength (nm)	405	445	457	473	488	515	633	638	647	660
Wavelength precision ¹ (nm)	± 5		+ 3 / - 7	± 5						
Spectral bandwidth (FWHM)	< 1.5 nm									
Output power ² (mW)	50 100	50	50	50 100	50 100	50	50	50	50	50

1. The wavelength is fixed with this accuracy. The wavelength is specified in air.
2. Power in continuous wave operation mode.

8.1.2. Optical specification for multi-line beam

Beam divergence, full angle	< 1.8 mrad
Spatial mode (TEM ₀₀)	M ² < 1.25
Beam diameter at aperture	700 ± 100 μm
Polarization extinction ratio	> 100:1, vertical
Beam symmetry	> 0.85 : 1
Noise 250 Hz - 2 MHz (% , rms)	< 0.3 %
Power stability over 8 hrs, ± 3°C	< 3.0 %
Beam position accuracy	< 0.5 mm
Beam angle accuracy	< 5 mrad
Ambient temperature & pointing - 20-50 °C	< 10 μrad/°C
Beam position overlap at exit	< 50 μm
Beam-to-beam angle deviation	< 250 μrad

* Noise typically increases after fiber coupling.

8.1.1. Modulation

	MLD	DPL
Digital modulation bandwidth	DC – 5 MHz	DC – 5 kHz
Digital modulation input signal impedance	10 MΩ	10 kΩ
Digital modulation Rise/Fall time	< 60 ns	< 60 μs
Digital modulation extinction ratio	> 70 dB (@1 MHz)	> 50 dB (@1 kHz)
Analog modulation bandwidth	DC- 500 kHz	DC – 5 kHz
Analog modulation input signal impedance	1 kΩ	
Analog modulation extinction ration	> 70 dB (@100 kHz)	> 50 dB (@1 kHz)
Analog modulation Rise/Fall time	< 1 μs	< 100 μs
Internal modulation bandwidth	Up to 500 Hz	
Internal modulation Rise/Fall time	< 100 μs	

8.1.2. Mechanical Interfaces

Laser head dimensions – Free beam	144 x 70 x 38 mm
Fixation holes, Laser head	∅ = 4 x 4.2 mm, 134 mm x 55 mm
Weight	< 0.6 kg
Laser head dimension – Fiber coupled	154 x 70 x 48 mm
Fixation holes, Laser head	∅ = 4 x 4.2 mm, 144 mm x 55 mm
Weight	< 0.8 kg

8.1.3. Operation and Environmental Specifications

Power supply requirements	12 VDC, 6.67 A
Intended use environment	Laboratory (indoor)
Pollution Degree	2
Power consumption, total system	60 W
Maximum baseplate temperature	50 °C
Ambient temperature, operation	10 - 40°C
Storage temperature	-10 °C to +60 °C
Humidity	0-90% RH non-condensing
Ambient Air pressure	950-1050 mbar
Heat sink thermal impedance at 40 °C ambient	< 0.17 K/W
Warm-up time from complete “off”	< 3 min
Communication protocol	USB or RS 232

8.1.4. Electrical interfaces

All equipment connected to the system should be limited energy as described by IEC 61010:1.

Interface	Location	Connector / pins
Input power	Laser Head	4 pin Molex (43650-0421)
Remote interlock connector	Laser Head	OEM : CTRL 10 pin Molex (87832-1020) / pin 1 and 2
Data port	Laser Head	USB-type mini B (USB or RS-232 communication)
Key control box connector	Laser Head	CTRL 10 pin Molex (87832-1020)
Digital modulation	Laser Head	SMB male (Laser 1 – Laser 4)
Analog modulation	Laser Head	SMB male (Laser 1 – Laser 4)
Laser Head connector	Key control box	VGA D-SUB 15-pin male
Remote Interlock connector	Key control box	CDRH : 3.5 mm audio female

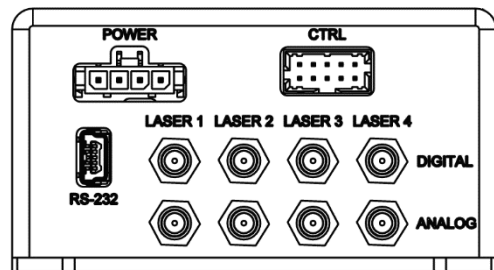

8.1.1. Integrated fiber coupled option

Coupling Efficiency	> 50 % per laser line into one fiber
Long-term stability (8 hrs ± 3°C) - out of the fiber	< 3 %
Fiber Output	FC / APC, 8°, non-collimated
Fiber Type	SM / PM
Polarization	PER > 30:1, ± 3° with respect to the key
Standard Fiber Length	2 m
Jacketing	Ø 3mm, PVC

* Noise typically increases after fiber coupling.

8.1.2. Fiber options

Art. Nr. 80100	Fiber and coupler : 405-640 nm, SM/PM, FC/APC, end-cap, Wide Key
Art. Nr. 80110	Fiber and coupler : 405-640 nm, SM/PM, FC/APC, end-cap, Narrow Key

8.2. Mechanical Drawings

8.2.1. Laser Head

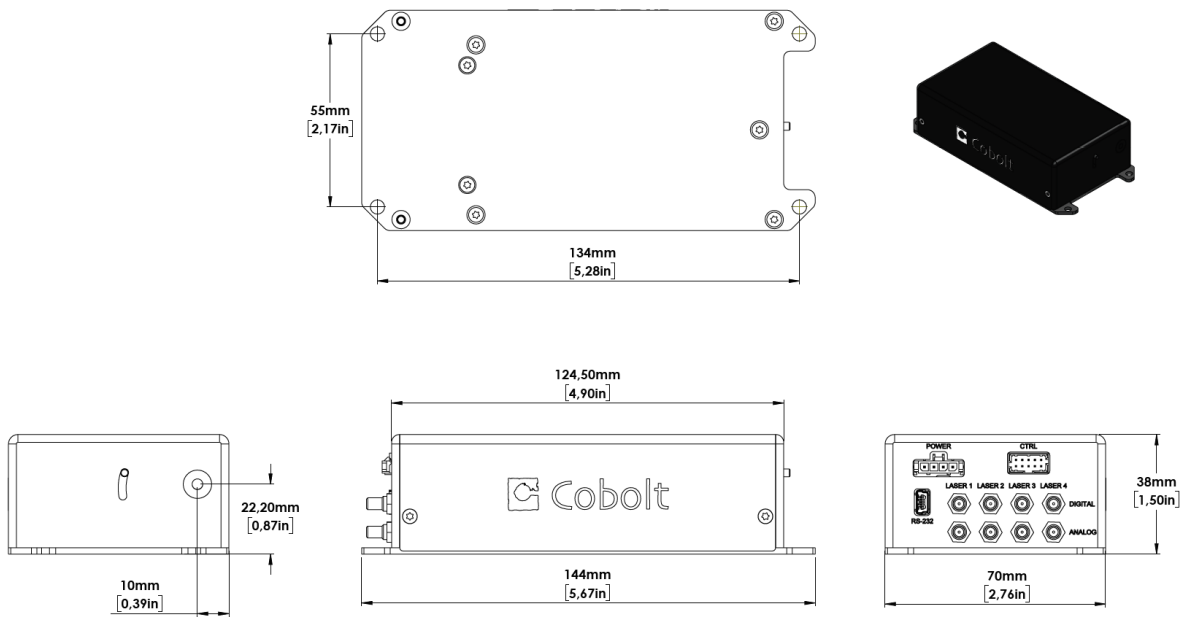

Free beam laser head mechanical outline. Dimensions in mm [inches].

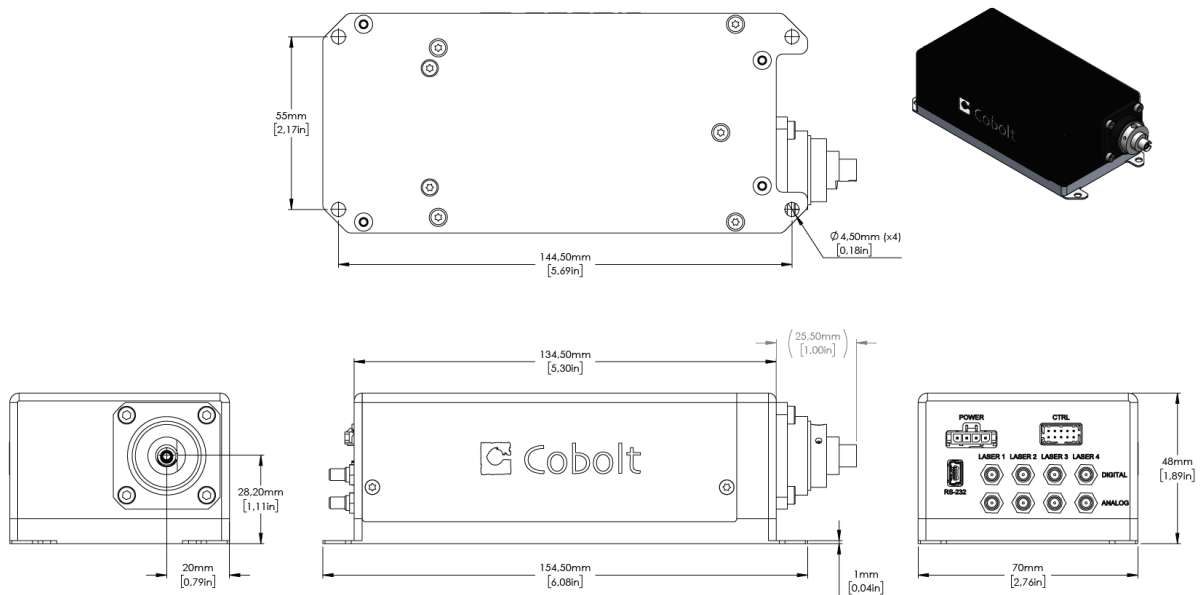

Fiber coupler compatible laser head mechanical outline. Dimensions in mm [inches].

8.2.2. Key control box

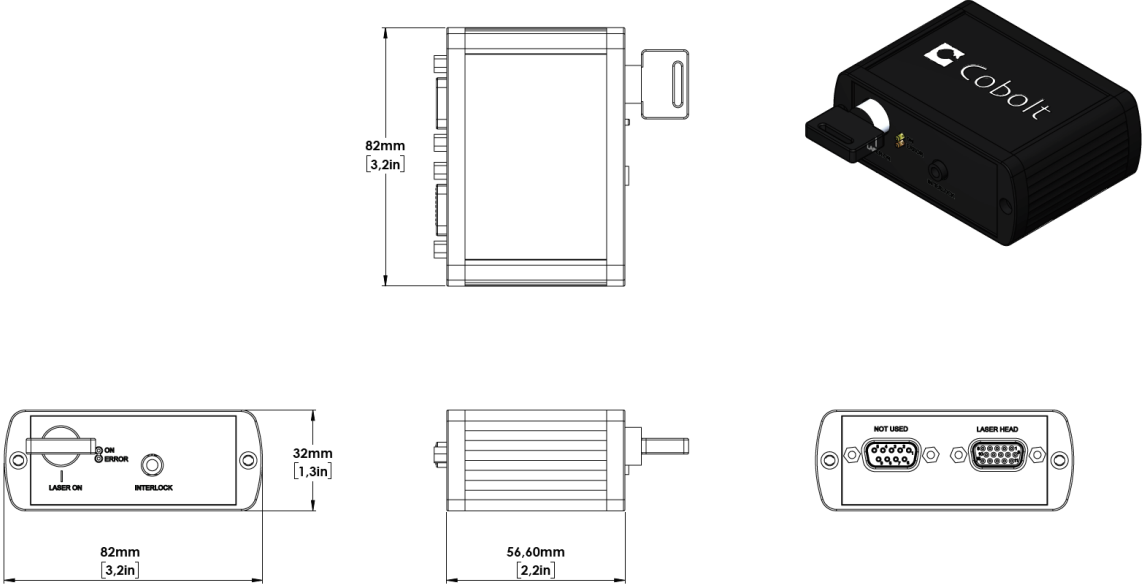

Key control box, mechanical outline. Dimensions in mm [inches].

8.3. Remote Interlock Connector

The laser is equipped with a remote interlock connector that prevents current flow through the diode when the circuit is open. After the remote interlock connector has been opened the laser will need to be reset by disconnecting from and then reconnecting to the power supply in order to start again, or toggling the key switch. Alternatively, it can be re-started using the 'clear fault' and 'laser on' commands, see Section 11.3 for further details. The signal level is between 0V and +5V with a pull up resistor, and the current required to ground the remote interlock connector is 5 mA. The time delay in the hardware is <math><1\text{ms}</math>, but after filtering by the firmware the reaction time is extended to <math><20\text{ms}</math>.

In OEM configuration the remote interlock connector is located at pin 1 and 2 of the Molex connector on the back side of the laser head. In CDRH configuration the remote interlock connector is located on the control box and a 3.5 mm mono plug is provided to short the circuit. To use the remote interlock connector with an external switch a 3.5 mm stereo plug is required. The ring and sleeve (see figure) must be connected for the laser to operate.

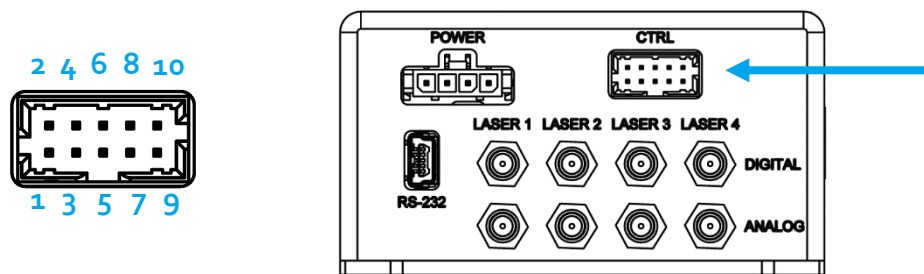

Molex connector on back side of laser head.

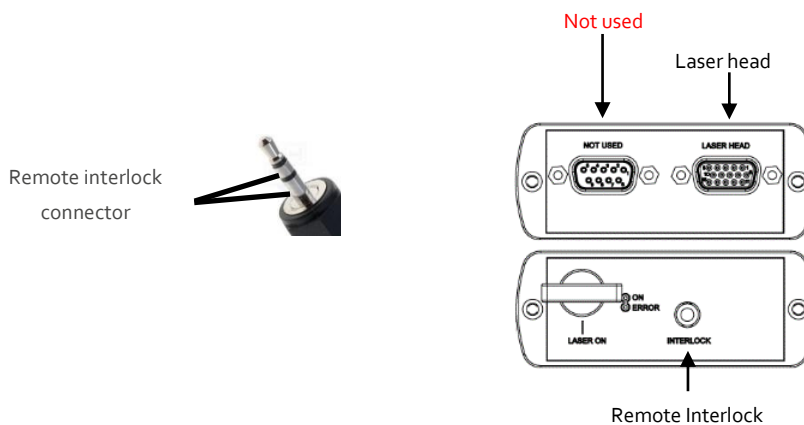

Remote interlock connector for control box.

8.4. Direct On/Off control

The Direct On/Off control feature enables turning the laser On/Off using a 5 VDC signal. After having configured the laser for Direct Input operation (factory set or by executing @cobasdr 1), the laser can only start-up when 5 VDC (max 12.5 VDC) is applied to pin 3 on the Molex connector with 0 VDC on pin 2 as reference. Shifting the signal to 0 VDC on pin 3 will turn the laser off and put the laser in stand-by mode. This input only controls the on/off state of the laser and cannot be used to modulate the power output. The remote interlock connection between pin 1 and 2 must also be made as described above.

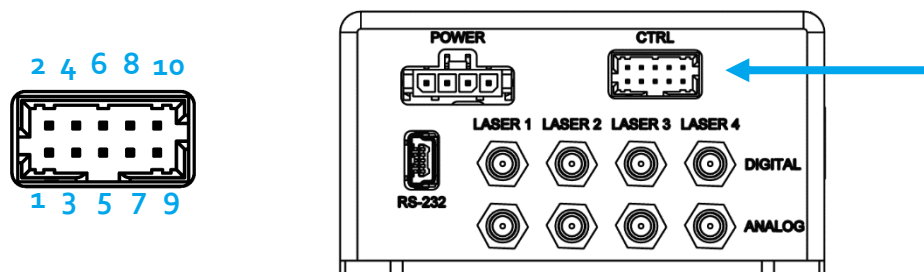

Molex connector on back side of laser head.

- ! **NOTE** Direct control is not available for CDRH compliant models and cannot be used with key control box.
- ! **NOTE** This input only controls the ON/OFF state of the device and cannot be used to modulate the output power of the laser.

8.5. Pin assignment

All equipment connected to the system should be limited energy as described by IEC 61010:1.

8.5.1. Laser head

The pin configuration for the 10 pin Molex connector on the laser head is described in the table below.

Pin	Signal
1	Remote interlock
2	0 V – Ground
3	Direct On/Off (+5 V Input) – OEM Only
4	Key Switch
5	LED 1A (Laser On)
6	LED 2 (Error)
7	LED 1B (Laser On - Redundant)
8	Not used (test)
9	Not used (Ground)
10	Not used (Ground)

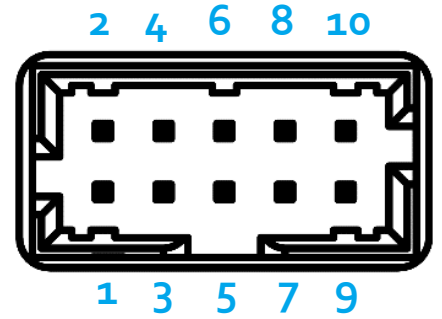

10 pin Molex socket on laser head

8.5.2. Data connector

Connector USB-type, manufacturer Hsuan Mao C8320-05BFDSBo, mates with connector mini-B.

Pin	Function
1	+5 V
2	D-
3	D+
4	Not connected
5	0 V (Ground)

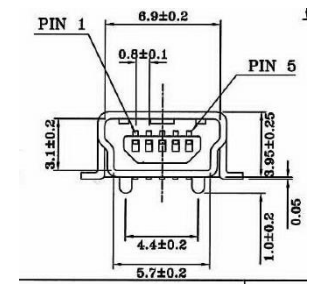

USB Connector

8.5.3. Power connector

The pin configuration for the Molex 4-pin connector is described below.

Pin	Function
1	0 V
2	0 V (connected to pin 1)
3	+12 VDC (connected to pin 4)
4	+12 VDC

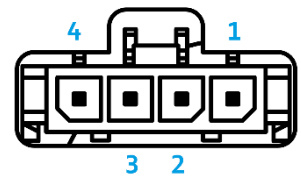

4 pin Molex socket on laser head

8.5.1. Key box

The pin configuration for the 15-pin D-SUB on the key control box are described in the table below.

Pin	Function
1	LED1 (A and B) - Laser on
2	LED2 - Error
3	<i>Not used</i>
4	0 V (ref pin 1,2,5,11)
5	Key Switch
6	<i>Not used</i>
7	<i>Not used</i>
8	<i>Not used</i>
9	<i>Not used</i>
10	0 V GND (ref pin 5)
11	Remote interlock connector
12	<i>Not used</i>
13	<i>Not used</i>
14	<i>Not used</i>
15	<i>Not used</i>

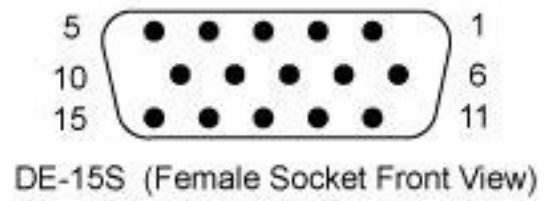
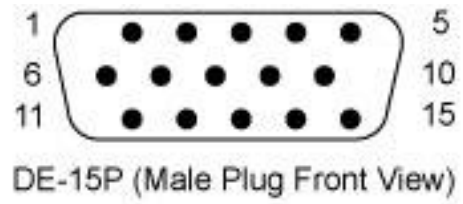

9. Continuous wave operation

Each laser line has two continuous-wave operating modes: **constant power** and **constant current**. The device is delivered with all laser lines in constant power mode. In constant current mode the laser runs at a set current level. The constant power setting is used to regulate the output power level.

- **Laser 1 : DPL** has a photodiode to monitor the power and actively adjust the current to maintain a stable output power.
- **Laser 2 / 3 / 4 : MLD** lasers do not have a power monitor photodiode. The displayed power is calibrated to the laser diode drive current at the factory and is read from an internal look up table.

9.1. Emission control in CW operation

The continuous wave operation modes are designed to optimize stability over long periods (hours) and should not be used for modulation. For details on fast control (> 1 Hz) of the laser emission see section 10 : Modulation mode operation.

The emission of each laser line can be controlled in several ways.

- **Restart / Abort** Controls the state of the device in autostart mode
- **Active / Inactive** Controls which laser lines are included the devices autostart sequence
- **ON / OFF buttons** Stops and starts emission of a single line, regardless of operation mode
- **Power level controls** Controls the output power level in constant power mode
- **Current level controls** Controls the output power level in constant current mode

The sections below describe how to apply each of the emission controls, where to find them in the Cobolt Monitor™ software interface and the corresponding commands. More details on all commands can be found in section 11.3 : Communication commands

RESTART / ABORT

The 'Restart' and 'Abort' buttons can be used to control all active lines in autostart mode, this will start the complete autostart sequence including temperature stabilization and warm up. Abort cancels the autostart sequence and places the entire device in an OFF state, no laser lines will emit. The LASER ON LED will no longer be illuminated and the key switch is required to restart the device when in CDRH mode. 'Restart' and 'Abort' are system level controls and will apply to all laser lines simultaneously.

The restart button corresponds to the system command 'restart', the abort button corresponds to the system command 'abort'. Neither command requires and argument.



ACTIVE / INACTIVE

The 'Active' check boxes can be used to enable and disable the laser lines and include them in the startup sequence. This function should only be used to control which lasers are included in autostart operation and not to control emission after startup. Disabled lines will not resume emission until they are marked active and turned ON, or until the device is restarted with the reactivate line included.

The 'Active' check box corresponds to the laser specific command '#sla X', set laser active state, where # is the number of the laser line being controlled and where X is 1 for ACTIVE or 0 for INACTIVE.

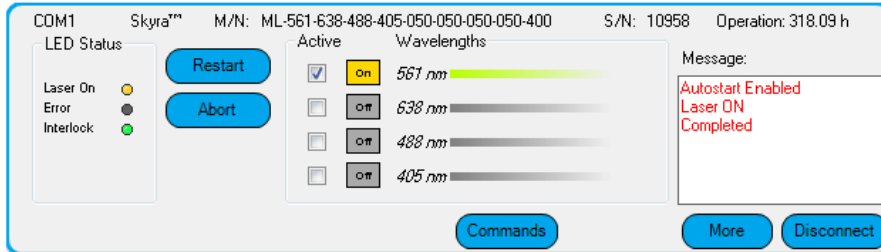

ON / OFF Button

The yellow ON / OFF buttons can be used to stop and start emission of a single laser line, regardless of the operation mode (constant power, constant current or modulation mode).

NOTE Turning the DPL ON and OFF changes the heat load on the TECs and will require some time for stabilization (< 2 minutes), this can affect some or all of the MLD laser lines as well.

Because the lasers lines are enabled from a laser safety point of view the Laser ON LED will remain illuminated even if each line is set to OFF. In autostart mode the laser will remain in the 'Completed' state and the key switch will need to be toggled ON and OFF.

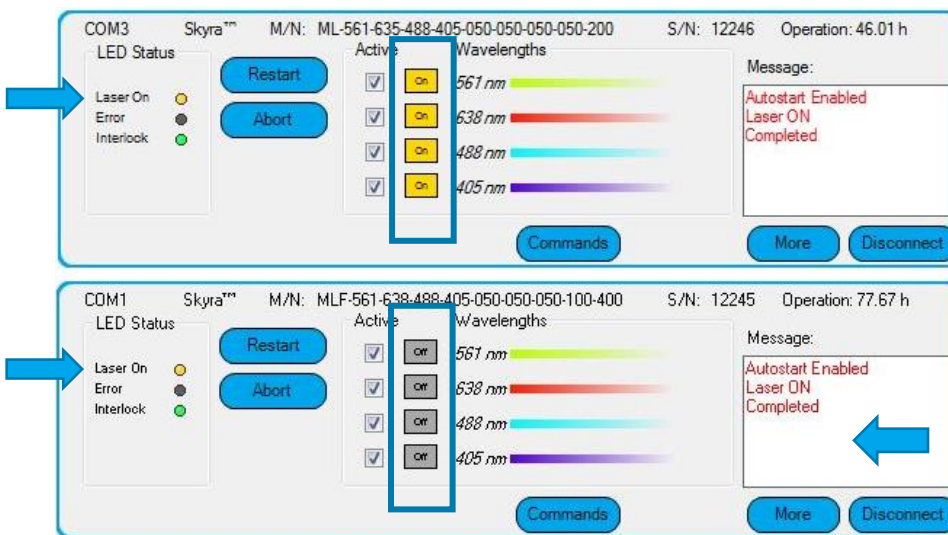

The ON and OFF button corresponds to the laser specific command '#l1' and '#lo', where # is the number of the laser line being controlled. It is not recommended to use the ON and OFF buttons to turn the laser ON and OFF repeatedly. See section 10 : Modulation mode operation for instructions on high speed emission control.

Power level controls

In constant power mode each laser line has a field where the output power can be set. In the case of the DPL the power controls are connected to a calibrated internal photodiode that delivers a real time power measurement and in the case of the MLD this is connected to a calibrated look up table to set the power. It is important to remember that though the output power can be changed the laser parameters are only guaranteed at 100% of nominal power.

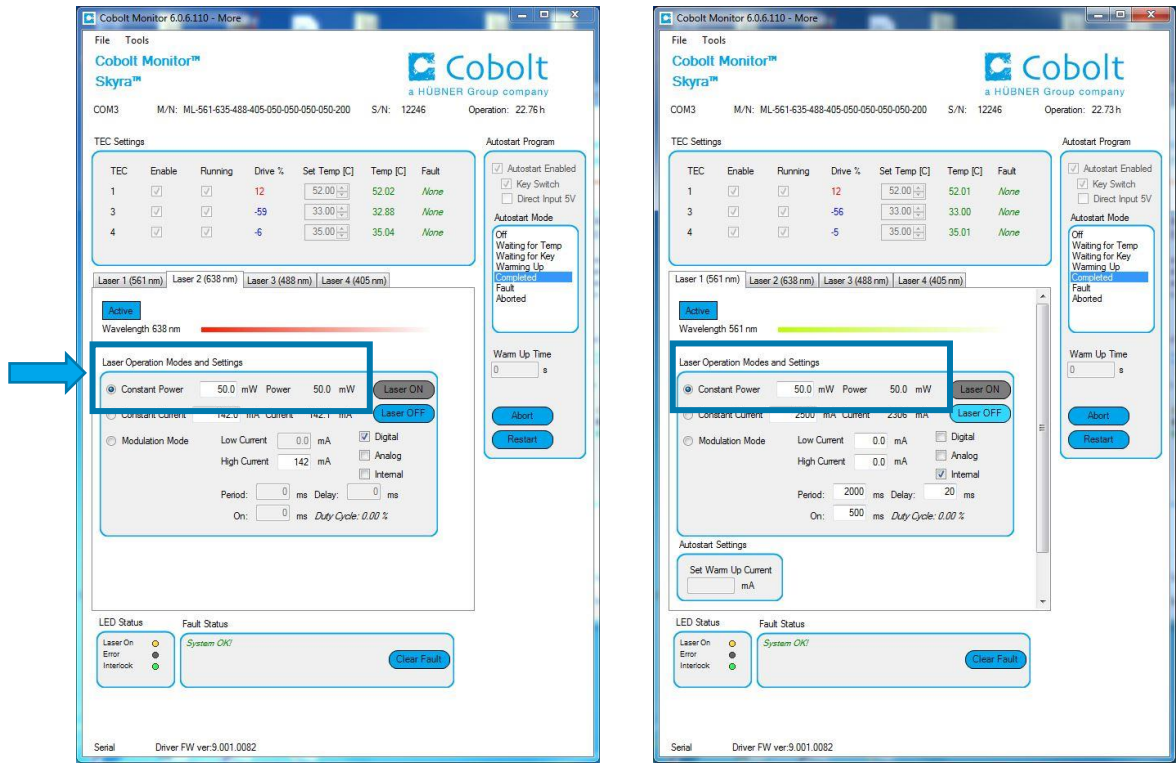

To read the power setting use the laser specific command #p?

The output power of a specific laser line can be set with the command '# X.X' where X.X is the power in Watts. For example, to set the DPL power to 25 mW the command is '1p 0.025'. The maximum allowed power is set at the factory.

The emission from a specific laser line can be stopped by sending the command to set the power to zero. For example, to set the DPL power to 0 mW the command is '1p 0'.

It is not recommended to use the power control to turn the laser ON and OFF repeatedly. See section 10 : Modulation mode operation for instructions on high speed emission control.

Current level controls

The laser output power can be controlled with the current setting in constant current mode. The current control can be used to toggle the laser between different current settings with commands, such as between the threshold current (low current) and the current setting that corresponds to the nominal output power. There are safety controls in place to prevent the user from exceeding the safe maximum current for any given laser line.

To read the current setting use the laser specific command '#i?'

The drive current, and therefore output power, of a specific laser line can be set with the command '#slc XXXX' where XXXX is the power in (milliamperes) mA. For example, to set the DPL current to 2500 mA the command is '1slc 2500'.

The emission from a specific laser line can be stopped by sending the command to set the current to zero. For example, to set the DPL current to 0 mA the command is '1slc 0'.

It is not recommended to use the current control to turn the laser ON and OFF repeatedly. See section 10 : Modulation mode operation for instructions on high speed emission control.

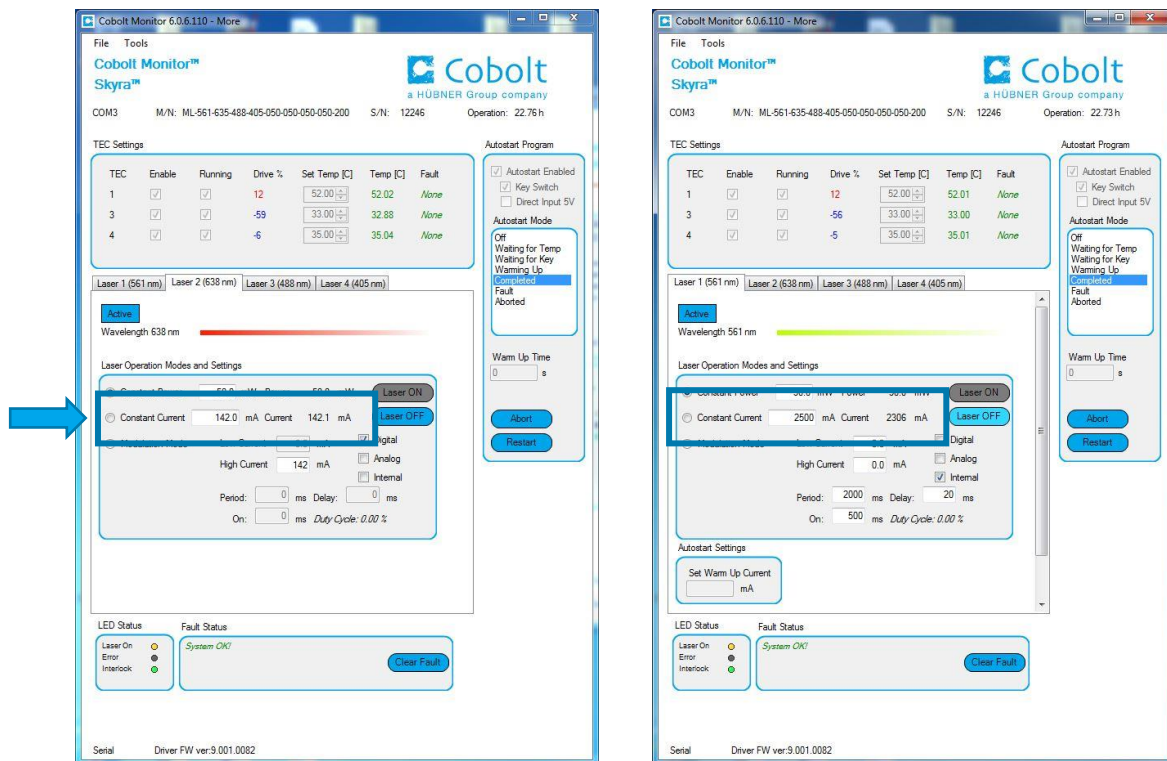

10. Modulation mode operation

Which modulation type to use?

Each laser line has three different modulation types: digital, analog and internal. These modulation types aim to cover most applications the user may have, and they each have very different specifications.

- **Digital modulation** allows for fast modulation speeds. Use digital modulation if you are modulating at high speeds in a square wave.
- **Analog modulation** is not as fast as digital but has the advantage that the user can drive the laser with arbitrary waveforms. Use this mode if you require arbitrary waveform. Analog modulation inputs can also be used to control the DC power level within the linear region of current to power relationship.
- **Internal modulation** allows the user to modulate the laser without an external modulation signal source.

	MLD	DPL
Digital modulation bandwidth	DC – 5 MHz	DC – 5 kHz
Analog modulation bandwidth	DC- 500 kHz	DC – 5 kHz
Internal modulation bandwidth	Up to 500 Hz	

Digital and Analog modulation can be used simultaneously in combination to give complicated output shapes such as pulse bursts. These combinations are dealt with separately at the end of this section. Switching between modulation types can be done using the Cobolt Monitor™ software or with direct commands. To control the laser emission in an irregular way with > 1 second ON time, or on a higher system level see section 9.1 : Emission control in CW operation.

Consideration when using modulation mode

The Laser 1: DPL laser line has a different temperature setting in modulation mode than in CW operation. Set the laser lines in modulation mode before starting modulation mode operation with enough time for temperatures to re-stabilize, this can take up to 2 minutes.

Always be sure to use the most appropriate modulation mode for the input signal frequency, contact your sales representative for support if it is not clear which modulation mode or combination of modes

The Laser 1 : DPL modulation parameters are set at the factory using a 1 kHz test signal, see section 10.5 : Settings Optimization in modulation mode (Laser 1 : DPL Only) for instructions on how fine tune the DPL setting to the intended modulation frequency and duty cycle.

10.1. Digital modulation

Digital modulation is the fastest modulation type; it has the largest bandwidth and shortest rise time. Digital modulation requires a 0-5V TTL input signal applied to the digital modulation input male SMB connector on the laser head, the duty cycle is set by the input signal. The diode current is modulated in a square wave.

To enable digital modulation using the Cobolt Monitor™ software, select “Modulation Mode”, and “Digital” under Modulation Type. Allow time for the temperature settings to re-stabilize after putting Laser 1 in modulation mode. The TEC3 setting will be changed when switching from CW to modulation mode on Laser 1 (DPL).

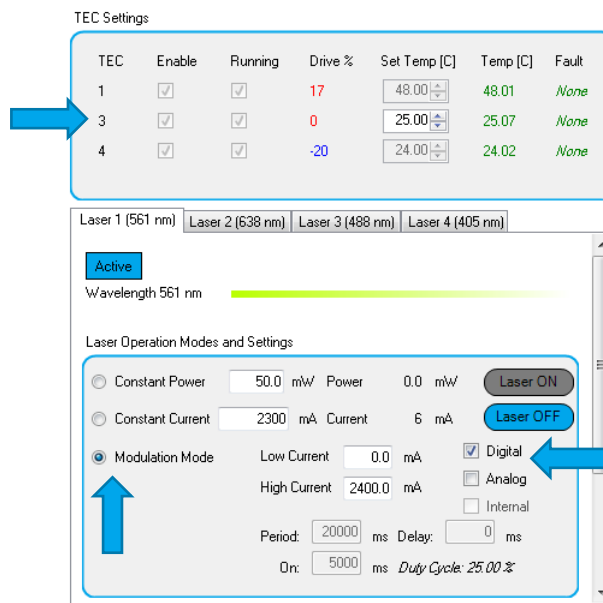

The power levels are controlled by the high and low current settings. The high current is set during manufacturing to achieve up to 100 % of the nominal power in the ON state. All parameters are optimized at the factory for performance at 1 kHz, with a 50% duty cycle.

For the DPL line (Laser 1) it is not always possible to reach 100% of nominal power in the ON state, in this case the High current level is set to the maximum of 3000 mA. The low current is set at the factory by visually inspecting the output beam and identifying the minimum current for emission, then lowering the value by 50 mA to ensure that the current is below the threshold. For the MLD lines (Laser 2, 3 and 4) the low current is 0 mA.

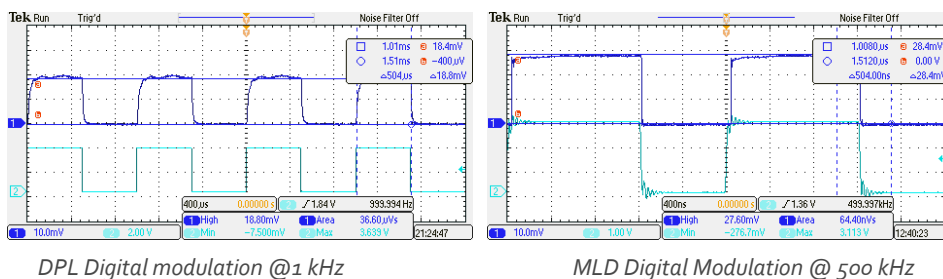

10.3. Internal modulation

Internal modulation is designed primarily for demonstration purposes. To enable internal modulation using the Cobolt Monitor™ software, select “Modulation Mode”, and “Internal” under Modulation Type. There are no external input signals required. The Cobolt Monitor™ software can be used to turn the current of each laser diode up and down to the ‘Low current’ and ‘High current’ set points with a maximum frequency of 500 Hz. Set the ‘Period’ and ‘On’ time to define the cycle for each laser and use the delay to control the relative start time for subsequent laser lines. The modulation sequence will start as soon as the internal modulation mode is enabled, by checking the internal modulation box. The ‘Delay’ setting is only meaningful when the lasers are started simultaneously, which can be achieved by using the ‘Restart’ button.

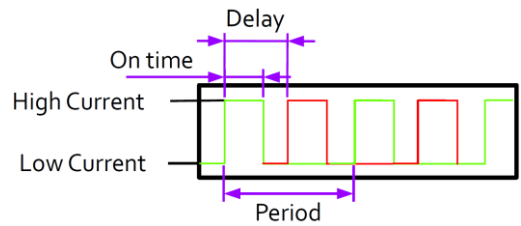
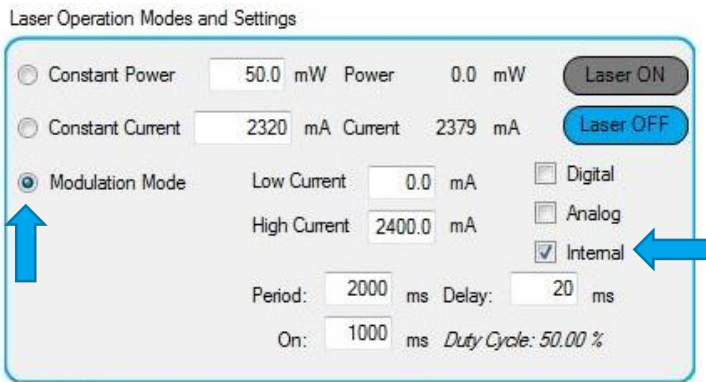

10.4. Modulation mode combinations

In addition to the modulation types described above, each laser line can be operated with a combination of modulation signals.

Analog + digital modulation

Each laser line can be used with hybrid digital + analog modulation. This can be accessed in the Cobolt Monitor™ software under the Modulation Mode option, as described in the previous sections separately. In this mode, whenever the digital state is ON, the laser runs at a power determined by the analog voltage. The analog and digital modulation described above can be combined where the digital modulation is the control signal that can switch the analog modulation on and off. The principle is schematically illustrated in the figure below.

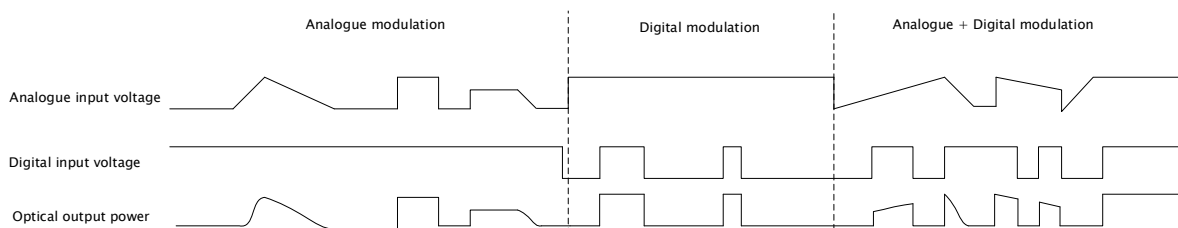

Schematic illustration of the three different modulation modes.

10.5. Settings Optimization in modulation mode (Laser 1 : DPL Only)

Cobolt Monitor™ software allows the user to optimize the laser performance while in modulation mode. During manufacturing the DPL settings are in digital modulation at 1 kHz and a 50% duty cycle. When modulating with a different input signal the user can expect changes in the pulse shape, peak power and average power. TEC 3, High current and Low current can be adjusted to re-optimize performance, though 100 % of the performance may not be recoverable.

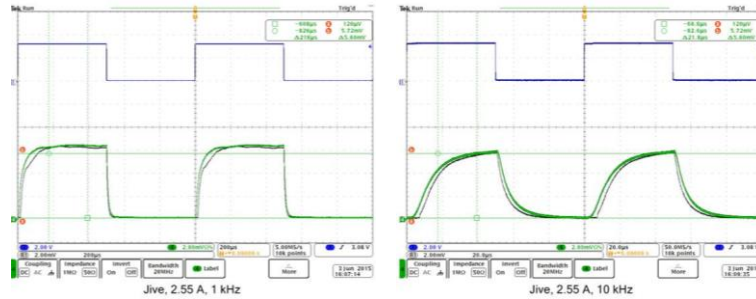

An example of the effect of modulation frequency on pulse shape at 1 kHz versus 10 kHz

TEC 3 Adjustment

TEC 3 is used to control the platform temperature when in modulation mode and can be used to optimize the temperature of the pump diode. Adjust the TEC 3 temperature inversely with duty cycle. The DPL’s optical output power is influenced heavily by the match between the pump diode’s emission spectrum and the laser crystal’s gain spectrum. Modulation mode operation is achieved by direct modulation of the drive current to the pump diode. Decreasing the ON time and thereby the diode temperature, must be compensated by an increase in the platform temperature to maintain a constant pump diode wavelength.

High Current Adjustment

It is not always sufficient to increase the TEC 3 temperature to achieve maximum average power. When necessary the High current level can be increased up to as much as 3000 mA, the maximum safe operating current for DPL as set at the factory.

Low Current Adjustment

If the application requires, it is possible to set the low current to 0 mA where a perfect dark state is required but adjusting the lower current can have adverse effects on pulse shape.

11. Operation via data port

To connect a Cobolt Skyra™ laser to a data port use mini-USB connection on the laser head for both RS-232 and USB communication. The appropriate cable is provided with all lasers.

11.1. Handshaking

Under no circumstances does the system initiate communication; it only transmits characters in response to a message. Every message generates a response, either a numerical value or the acknowledgment string "OK". In the event that the system receives a message that it cannot interpret, it responds: "Syntax error: illegal command". Every system response is terminated by a carriage return (ASCII 13) and a full stop is used with floating numbers.

11.1.1. RS232 configured controllers

To communicate with the laser, a communication cable is supplied. Each Controller is shipped from the factory with a fixed baud rate (115200). The other serial port parameters are: 8 data bits, 1 stop bit and no parity. Hardware flow control is not supported. Each command to the Controller must be terminated by a carriage return. All commands are case-sensitive. Leading and trailing white space is ignored, but command arguments must be delimited by a single space character (ASCII 32).

11.2. USB driver

When using Cobolt Monitor™ with Windows 10, the USB device is automatically detected. When using Windows 8 or earlier (e.g Windows 7, Vista, XP) it is necessary to install the Cobolt signed USB driver. To be able to connect to a Cobolt Skyra™ laser via USB, a USB driver must be installed on the computer. The USB driver can be downloaded from the Cobolt website (www.coboltlasers.com). When installed, a virtual COM port will be created to communicate with the laser. To install the USB driver in Windows 7 follow these instructions:

1. Go to the **Control Panel** and choose **Hardware and Sound**.

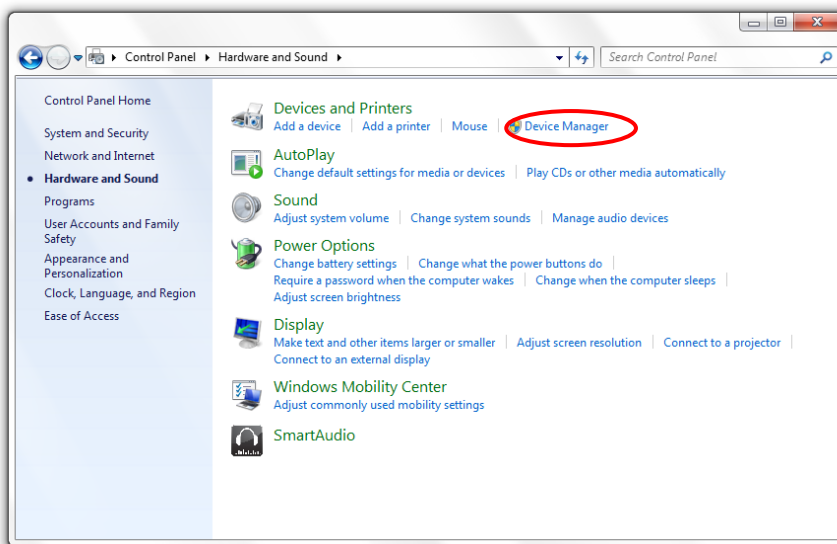

2. Under the **Devices and Printers** section, choose **Device Manager**.
3. Under **Other devices**, find the device called **Cobolt Laser Driver**. Right-click it and chose **Update Driver**

Software.

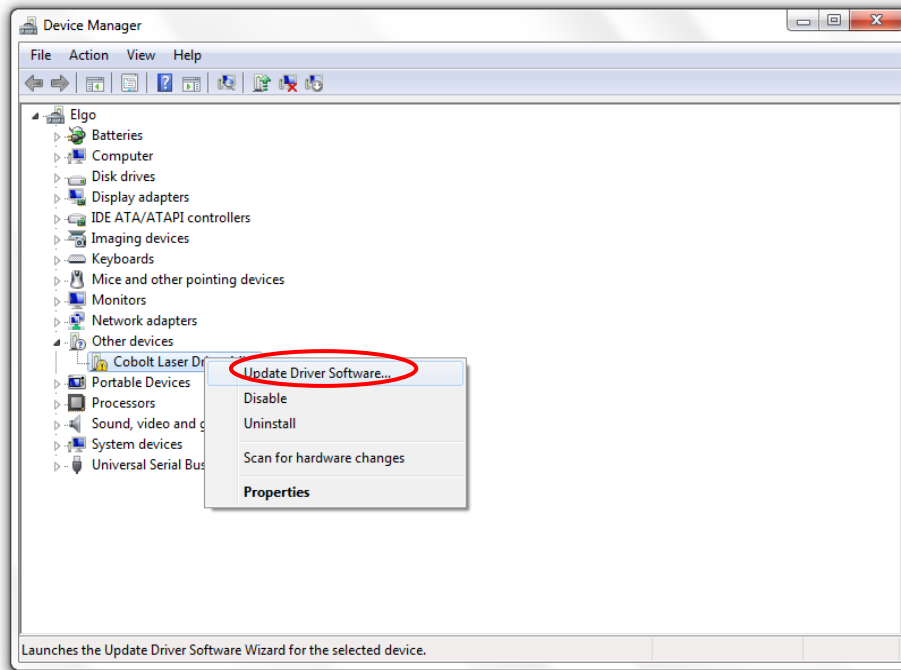

4. On the next screen chose the **Browse my computer for driver software** option.

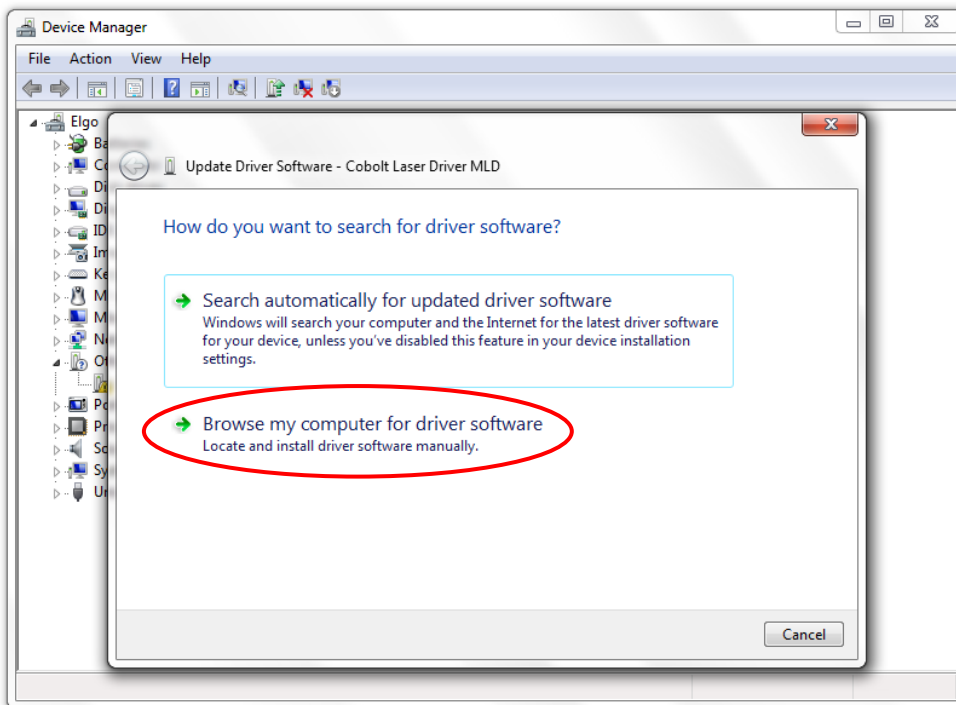

5. Click **browse**, and find folder on your computer where the USB driver is stored.

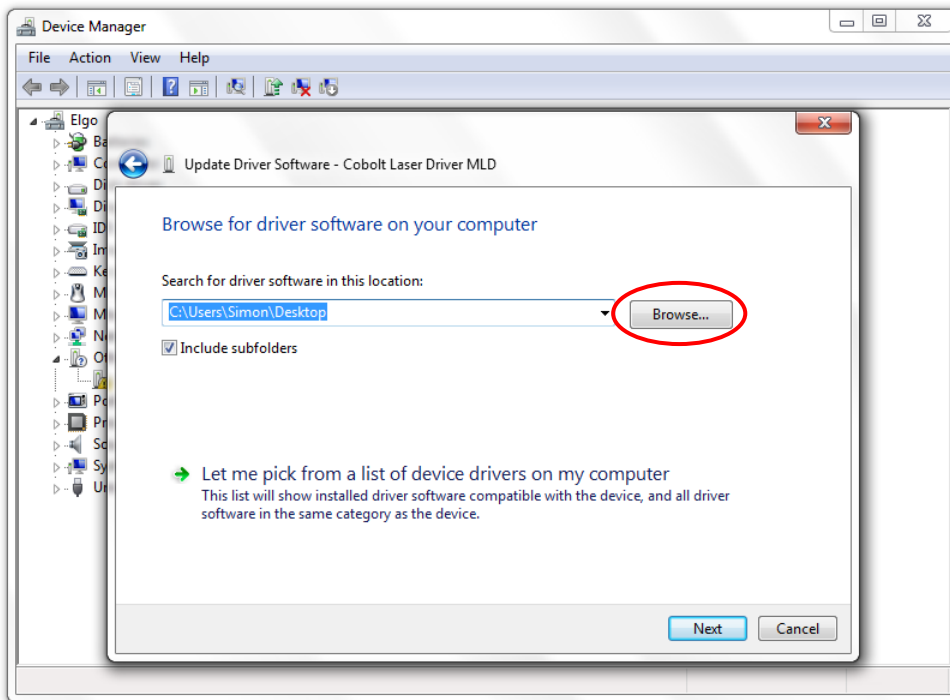

6. Windows security may warn you that the publisher of the driver is unverified. Choose **Install this driver software anyway**.

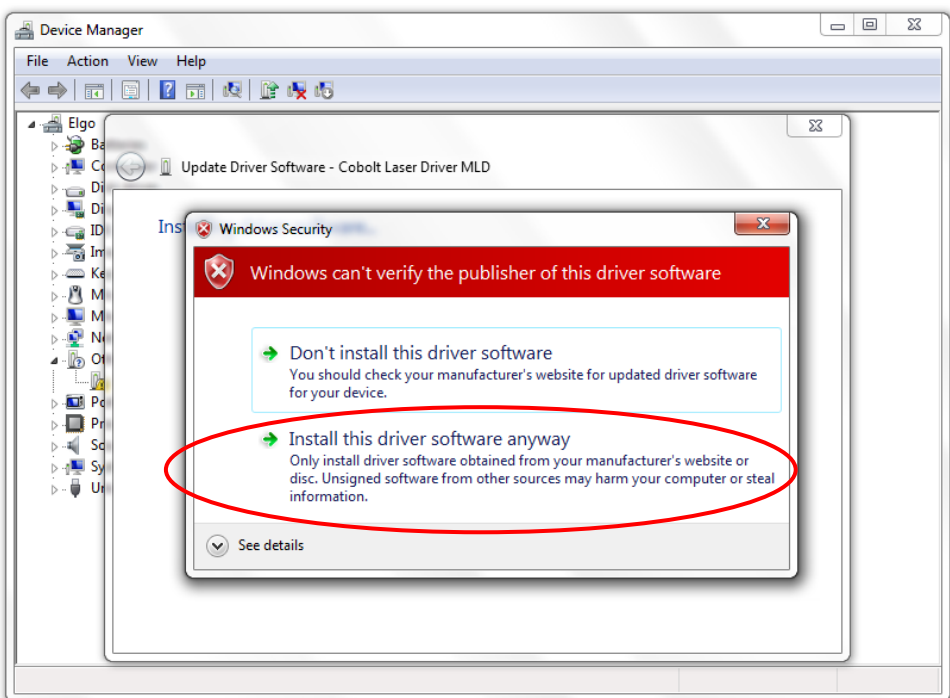

7. The installation should now be complete.

11.3. Communication commands

The laser is delivered in Auto-start mode (see section 3 for Auto-start sequence description). For system integration the Auto-start sequence can be disabled, and the following commands can be used to control the laser (NOTE some commands require Auto-start to be disabled but others will work when Auto-start is active). As long as power is supplied to the laser the temperature control elements are always operating to reach set-point values and the laser will be idle waiting for the next command. All arguments are in lower case and separated by a space (ASCII 32).

! **NOTE** The default settings are not stored in the device. Once a set point has been changed the original cannot be automatically restored. All factory settings are archived at the manufacturer. If the system has been modified and the default settings lost contact your sales representative.

System Commands

The following commands are relevant for the Cobolt Skyra laser system. For control commands relevant to individual laser lines, see section 'Laser Specific Commands'

Command	Function	Argument	Returned value
?	Are you there?		'OK = Laser responding
l1	All lasers ON. If 'Autostart' is enabled the start-up sequence will 'Restart'. If 'Autostart' is disabled all laser will go directly into an ON state.	-	-
@cob1	All lasers ON. If 'Autostart' is enabled the Autostart sequence will 'Restart'. If 'Autostart' is disabled the laser will go through a forced Autostart sequence.	-	-
l0	All lasers OFF. If 'Autostart' is enabled the start-up sequence will 'Abort'. If 'Autostart' is disabled all laser will go directly into an OFF state.	-	-
@cob0	All lasers off. If 'Autostart' is enabled the start-up sequence will 'Abort'. If 'Autostart' is disabled all laser will go directly into an OFF state.	-	-
abort	Abort Aborts Autostart sequence and sets laser in 'Aborted' mode. The TECs are driving but there is no emission possible.		-
restart	Restart system Starts Autostart sequence.		
gom?	Get operating mode		0 = Off 1 = Waiting for temp 2 = Waiting for key 3 = Warm-up 4 = Completed 5 = Fault 6 = Aborted
@cobasks?	Get key switch state		0 = Key in OFF position 1 = Key in ON position

gtec3tm?	Get TEC ₃ temperature in modulation mode		Float (°C)
stec3tm	Set TEC ₃ temperature in modulation mode	Float (°C)	
f?	Get operating fault		0 = no fault 1 = temperature error 3 = open interlock 4 = constant power fault
cf	Clear fault		
ilk?	Read interlock state		0 = Interlock closed 1 = Interlock open
sn?	Get laser serial number		32-bit unsigned integer
hrs?	Get system operating hours		Float (h)

Laser Specific Commands

To address a particular laser the command must be prefaced with the laser number and with a space between the command and the argument. There is no space between the laser number and the command.

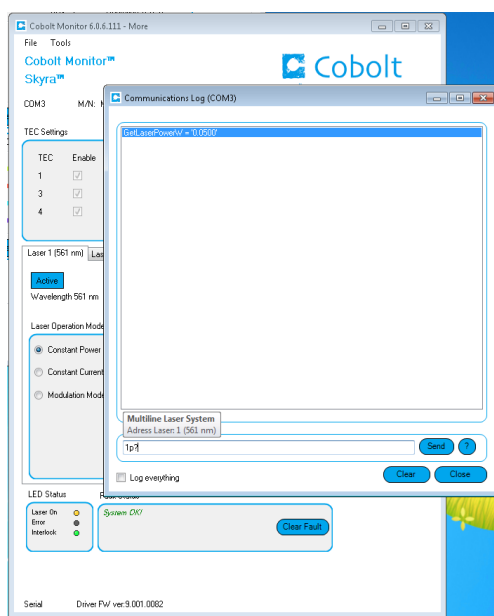

[Laser #][command] [argument]

Command	Function	Argument	Returned value
#glw?	Get laser wavelength	Float (nm)	
#gla?	Get laser active state		0 = Inactive 1 = Active
#sla	Set laser active state When a laser line in active it will be included in the autostart sequence. When inactive, it will not.	0 = Inactive 1 = Active	
#l?	Get laser ON/OFF state		0 = OFF 1 = ON

#l1	Turn laser line ON		
#l0	Turn laser line OFF		
#cp	Enter constant power mode		
#p	Set laser power (W)	Float (W)	
#p?	Get laser power setting (W)		Float (W)
#pa?	Read laser power (W)		Float (W)
#ci	Enter constant current mode		
#slc	Set laser current (mA)	Float (mA)	
#glc?	Get laser current (mA)		Float (mA)
#i?	Read laser current (mA)		Float (mA)
#em	Enter modulation mode		
#gmes?	Get modulation enabled state		0 = disabled 1 = enabled
#gmc?	Gets the modulation current, modulation high current		Float (mA)
#smc	Set a modulation current, modulation high current	Float (mA)	
#glth	Get lower threshold, modulation low current		Float (mA)
#slth	Set lower threshold, modulation low current	Float (mA)	
#gdmes?	Get digital modulation enabled state		0 = disabled 1 = enabled
#sdmes	Set digital modulation enabled state	0 = disable 1 = enable	
#games?	Get analog modulation enabled state		0 = disabled 1 = enabled
#sames	Set analog modulation enabled state	0 = disable 1 = enable	
#eswm	Enable software modulation		
#gswm?	Get software modulation enabled state		0 = disable 1 = enable
#sswmp	Set software modulation period	Float (ms)	
#gswmp?	Get software modulation period		Float (ms)
#sswmo	Set software modulation On	Float (ms)	
#gswmo?	Get software modulation On		Float (ms)
#sswmod	Set software modulation On Delay	Float (ms)	
#gswmod?	Get software modulation On Delay		Float (ms)

12. Troubleshooting

Below are some possible problems along with a list of things to check if the problem occurs.

No laser emission 3 minutes after start-up

1. Verify the remote interlock connector is connected and restart the laser.
2. Verify that autostart is enabled. Click the restart button in the Monitor software or send the command "@cob1" to force a restart of the laser.
3. Verify that the laser lines are 'Active' by sending the command '#sla 1', for all 4 lines (#= 1,2,3 and 4)
4. Ensure the laser has adequate heat sinking.
5. Verify the supply voltage is within the range stated in section 7.6.
6. Check the base plate temperature (this is displayed in the Cobolt Monitor™ software). If it is outside of the range 20-50 °C the laser may take longer to stabilize the temperature, or be unable to do so.
7. Send the command "f?"
8. If fault code 1 is returned, check that the heat sink is adequate and that the ambient temperature is under 40°C.
9. If fault code 3 is returned, see interlock fault checklist.
10. If fault code 4 is returned, there may be a problem with the constant power system.
11. Contact Cobolt technical support.

Interlock fault

1. If using a custom interlock system, connect the Cobolt-supplied remote interlock connector plug to check whether the interlock is correctly wired.
2. This remote interlock connector should be connected as described in section 8.3.
3. In the software, check that "Interlock Fault" is not displayed. Send the command "ilk?" to confirm the Remote Remote interlock connector is not open (returns a 1 if closed).
4. If it is verified that the Remote Interlock Connector system is closed yet an interlock fault is returned, contact Cobolt technical support.

Laser emission stops

1. Ensure the laser has adequate heat sinking.
2. Check that the Remote Interlock Connector is connected.
3. Send the command "f?"
4. If fault code 1 is returned, check that the heat sink is adequate and that the ambient temperature is under 40°C.
5. If fault code 3 is returned, see interlock fault checklist.
6. If fault code 4 is returned, there may be a problem with the constant power system.
7. Contact Cobolt technical support.

Low power

1. Check that the laser is in constant power mode (using the GUI or the "cp" command).
2. Check the power reading using the GUI or the "pa?" command.
3. If this does not agree with the real output power, re-calibrate by measuring the power and entering it in the "Power Cal" box in the software.
4. Send the command "f?". If fault code 4 is returned, there may be a problem with the constant power system.
5. Contact Cobolt technical support.

13. Warranty and Maintenance

The Cobolt lasers should not be opened for any reason. The warranty will be void if any of the system units are opened. All laser parameters are set at the factory, and there are no adjustments required (other than those described in this manual for operating in different modulation modes and at different power levels). Fibers and fiber couplers delivered with the system are not covered under that lasers warranty.

Cobolt provides a warranty of 12 months after delivery with unlimited hours of operation. The laser systems are designed for modular replacement or repair in the event that the laser head or key control box malfunctions. Warranty is invalid if the laser system is operated outside of the specific limits and conditions as outlined in this document.

14. Service

Due to accuracy tolerances, calibration differences and allowed power drift there may be discrepancies between the Cobolt measurement of the optical output power and the customer measurement equipment. If the output power deviates from the reported value please contact your local Cobolt representative for an online re-calibration.

If an RMA number is issued and the laser needs to be shipped back to Cobolt or your local representative, please pack the complete system for shipment using the original package or equivalent. Ensure the unit is free from thermal paste before packing. The warranty covers repair or replacing the unit at the option of Cobolt.

15. Disclaimer

Cobolt will assume no responsibility for damage incurred by faulty customer equipment, such as measurement equipment, cables etc, used in conjunction with Cobolt lasers. Cobolt makes no warranty of any kind with regard to the information contained in this guide, included but not limited to, implied warranties of merchantability and suitability for a particular purpose. Cobolt shall not be liable for errors contained herein nor for incidental or consequential damages from the furnishing of this information. No part in this manual may be copied, reproduced, recorded, transmitted, or translated without the express written permission by Cobolt.

16. Compliance (CDRH models only)

The CDRH model lasers (-1/300) are designed and manufactured to comply with the EC Low Voltage Directive and the EC EMC Directive in the CDRH-compliant configuration of laser head, key control box, key and Cobolt-supplied power supply. All equipment must be mounted on a common ground plane, such as an optical table. If any part of the delivered equipment is replaced with a part not supplied by Cobolt or if the equipment is not properly grounded, the system may not conform to CE / CDRH compliance standards listed in section 16. Disabling any of the safety features nullifies the CE marking and violates the laser safety standard.



The following harmonized and limits standards have been applied:

Electrical Safety	EN 61010-1, IEC-61010-1, UL 61010-1 (Limited Energy System) UK S.I. 2016 No. 1101 : The Electrical Equipment (Safety) Regulations 2016
Laser Safety/Class	IEC-60825-1 FDA / CDRH : Complies with 21 CFR 1040.10 and 1040.11 except for conformance with IEC 60825-1 Ed. 3., as described in Laser Notice No. 56, dated May 8, 2019.
EMC	IEC 61326-1 EN 55011 Electromagnetic Emission , Class B Electromagnetic Immunity – Table 2 Requirements EN 61000-4-2 Electrostatic Discharge ±4 kV contact discharge and ±2 kV, ±4 kV, ±8 kV air discharge EN 61000-4-3 Radiated electromagnetic fields 80 – 1000 MHz, 10 V/m with 80 % AM @ 1 kHz 1.4 – 2.0 GHz, 10 V/m with 80 % AM @ 1 kHz EN 61000-4-4 Fast transient / Burst AC Power input port ±2,0 kV EN 61000-4-5 Surge AC Power input port ±0,5 kV, ±1,0 kV, ±2,0 kV Com. Mode AC Power input port, ±0,5 kV, ±1,0 kV Diff. Mode EN 61000-4-6 Conducted Immunity 10 V with 80 % AM @ 1 kHz EN 61000-4-11 Dips and Interruptions 50 Hz and 60 Hz. Test voltages: 100 V and 230 V UK S.I. 2016 No. 1091 : Electromagnetic Compatibility Regulations 2016 FCC 47 CFR - Part 15 (2009): Subpart B, Class B
RoHS	EU Directive 2011/65/EU, EU 2015/863 and amendment EU 2017/2102 UK S.I. 2012 No. 3032

Contact your sales representative for a copy of the full Declaration of Conformity.



Our Locations

Cobolt AB

(Sales in Norway, Sweden, Finland and Denmark)

Solna, Sweden

Phone: +46 8 545 912 30

Fax: +46 8 545 912 31

E-mail: info@coboltlasers.com

HÜBNER GmbH & Co. KG

(Sales in Germany, Switzerland and Austria)

Kassel, Germany

Phone: +49 6251 770 6686

Fax: +49 6251 860 9917

E-mail: photonics@hubner-germany.com

HÜBNER Photonics Inc.

(Sales in USA, Canada and Mexico)

San Jose, California, USA

Phone: +1 (408) 708 4351

Fax: +1 (408) 490 2774

E-mail: info.usa@hubner-photonics.com

HÜBNER Photonics UK

(Sales in UK and Ireland)

Derby, Great Britain

Phone: +44 2380 438701

E-mail: info.uk@hubner-photonics.com

www.hubner-photonics.com

Australia

Warsash Scientific Pty Ltd

www.warsash.com.au

Benelux

Laser 2000 Benelux CV

www.laser2000.nl

Brazil

Photonics Instrumentos

www.photonics.com.br

China

DynaSense Photonics Co. Ltd.

www.dyna-sense.com

Estonia, Latvia and Lithuania

Optek Ltd

www.optek.lv

France

Optoprim

www.optoprim.com

India

Spectral Instrument System

www.spectralinstruments.com

Israel

Lahat Technologies Ltd

www.lahat.co.il

Italy

Crisel Instruments

www.crisel-instruments.com

Japan

Kantum Electronics Co Ltd

www.kantum.co.jp

Pneum Co, Ltd Japan

www.pneum.co.jp

Poland

Amecam

www.amecam.pl

Russia and Belarus

Azimuth Photonics

www.azimp.ru

Russia and Belarus

Azimuth Photonics

www.azimp.ru

South Korea

BM Laser Solutions Co., Ltd

www.bmlaser.co.kr

SM Tech

www.lasersystem.co.kr

Singapore, Malaysia and Thailand

Wavelength Opto-Electronic

www.wavelength-tech.com

Spain and Portugal

Laser Technology SI

www.laser-technology.com

Taiwan

Tayhwa Technology Co Ltd

www.tayhwa.com.tw

HÜBNER Photonics

